



Centreline BIM
Designing better, Tomorrow

INTERIOR DETAIL DRAWING



WWW.CENTRELINEBIM.COM



+91 95440 55556



WRITEUS@CENTRELINEBIM.COM



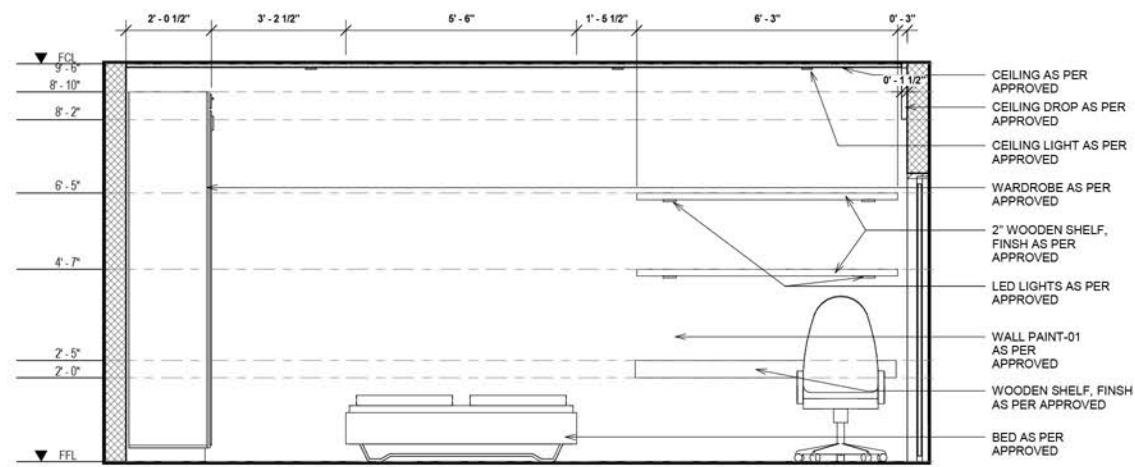

A ELEVATION A
1:25

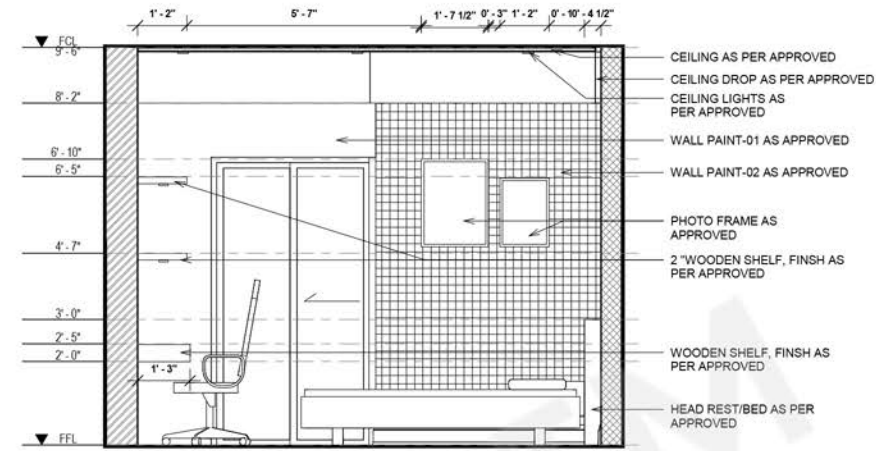

B ELEVATION B
1:25

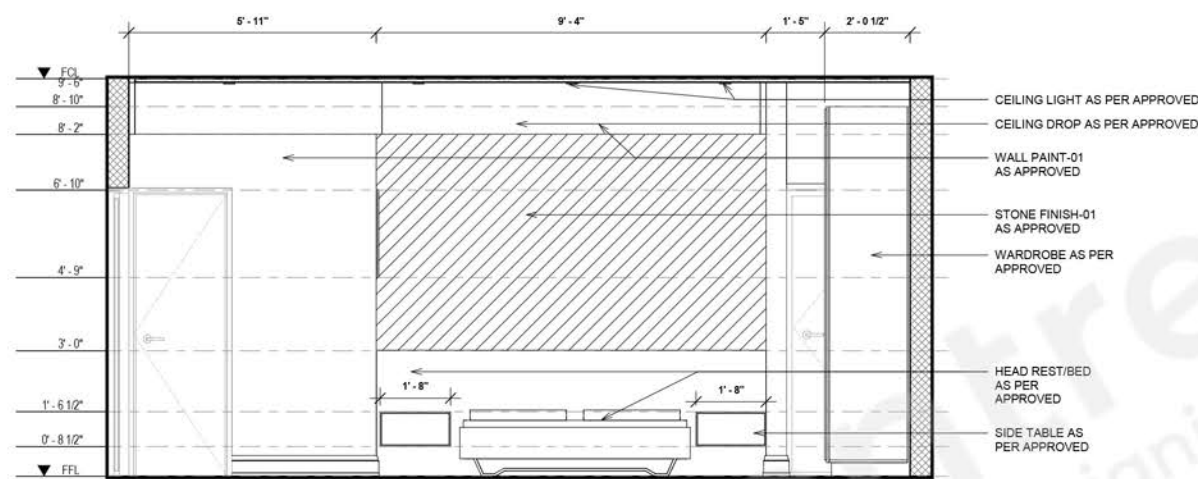

C ELEVATION C
1:25

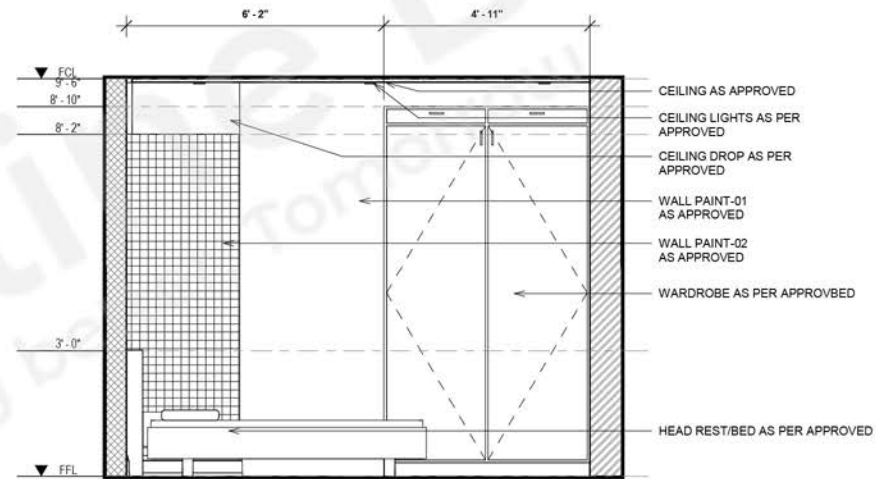

D ELEVATION D
1:25

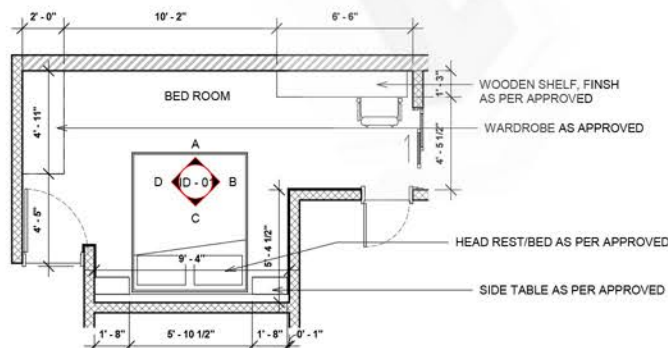

1 BED ROOM - PLAN
1:50

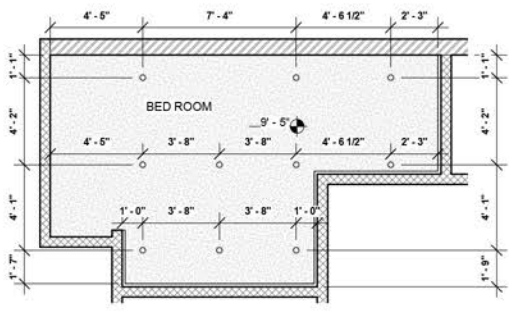

2 BED ROOM - RCP
1:50



RENDER IMAGE - 01

IMPORTANT NOTES:
CONTRACTOR TO VERIFY ALL DIMENSIONS ON SITE. SHOULD ANY DISCREPANCIES OCCUR CONTACT DESIGNER IMMEDIATELY.
REFER TO FINISHES SCHEDULE FOR FINAL FINISHES.
ALL DIMENSIONS TO BE CHECKED ON SITE PRIOR TO COMMENCEMENT OF WORKS.
DO NOT SCALE OFF DRAWINGS.

FOR APPROVAL
NOT FOR CONSTRUCTION

KEY PLAN

REVISION	DATE	DESCRIPTION	BY

BIM CONSULTANT

CLIENT
DEVELOPMENT MANAGER
CONTRACTOR

PROJECT

DRAWING TITLE
BEDROOM

SCALE	DATE	DRAWN	CHECKED
As indicated @A1			
JOB	DRAWING	REVISION	
	ID - 01		

IMPORTANT NOTES:
 CONTRACTOR TO VERIFY ALL DIMENSIONS ON SITE. SHOULD ANY DISCREPANCIES OCCUR CONTACT DESIGNER IMMEDIATELY.
 REFER TO FINISHES SCHEDULE FOR FINAL FINISHES.
 ALL DIMENSIONS TO BE CHECKED ON SITE PRIOR TO COMMENCEMENT OF WORKS.
 DO NOT SCALE OFF DRAWINGS.

FOR APPROVAL
 NOT FOR CONSTRUCTION

KEY PLAN

REVISION	DATE	DESCRIPTION	BY

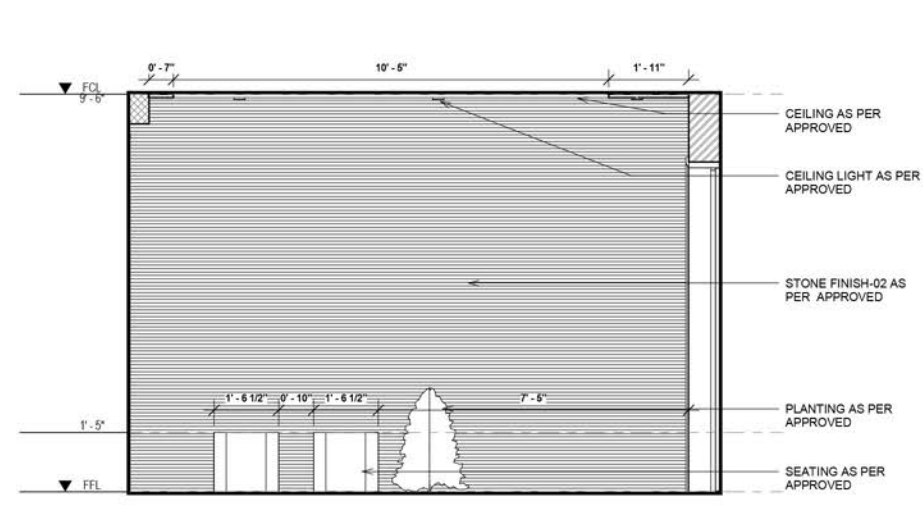

A ELEVATION - A
 1 : 25

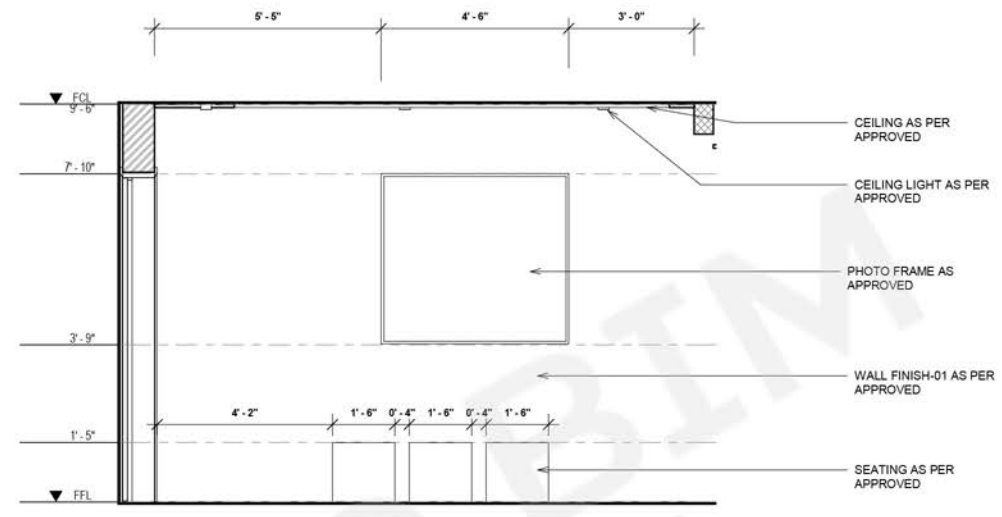

B ELEVATION - B
 1 : 25

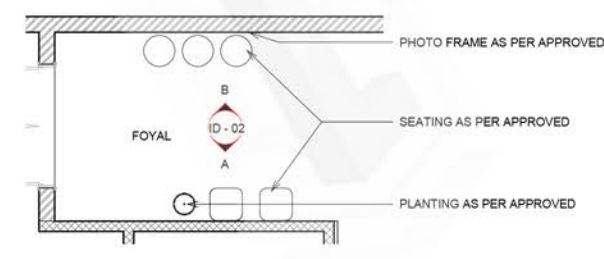

3 FOYER - PLAN
 1 : 50

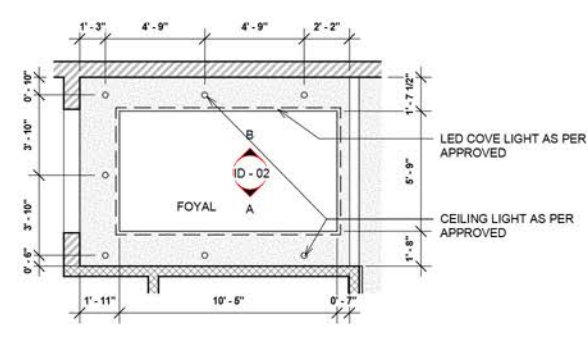

4 FOYER - RCP
 1 : 50



RENDER IMAGE - 01

BIM CONSULTANT

CLIENT

DEVELOPMENT MANAGER

CONTRACTOR

PROJECT

DRAWING TITLE
FOYER

SCALE	DATE	DRAWN	CHECKED
As indicated @A1			
JOB	DRAWING	REVISION	
	ID - 02		

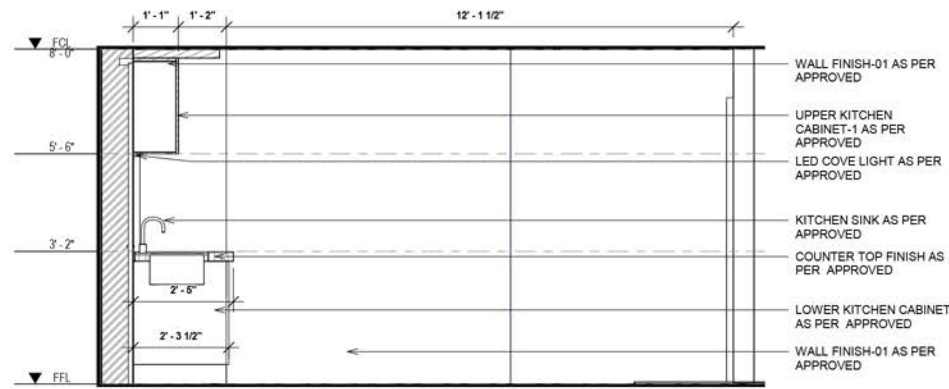

A ELEVATION - A
1: 25

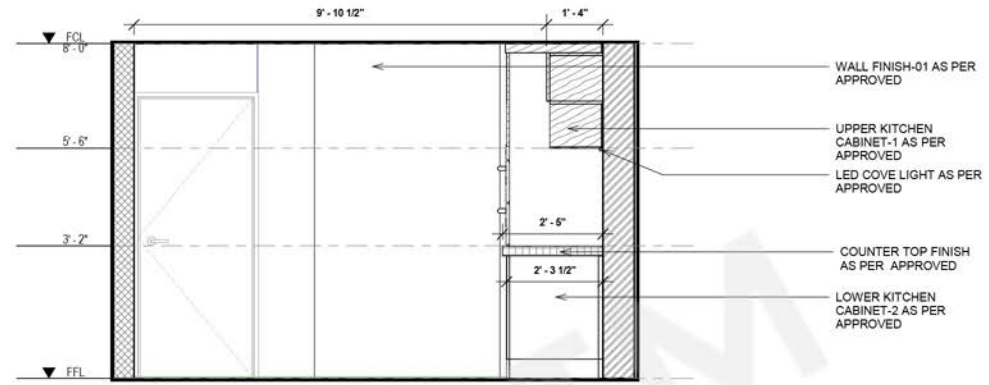

B ELEVATION - B
1: 25

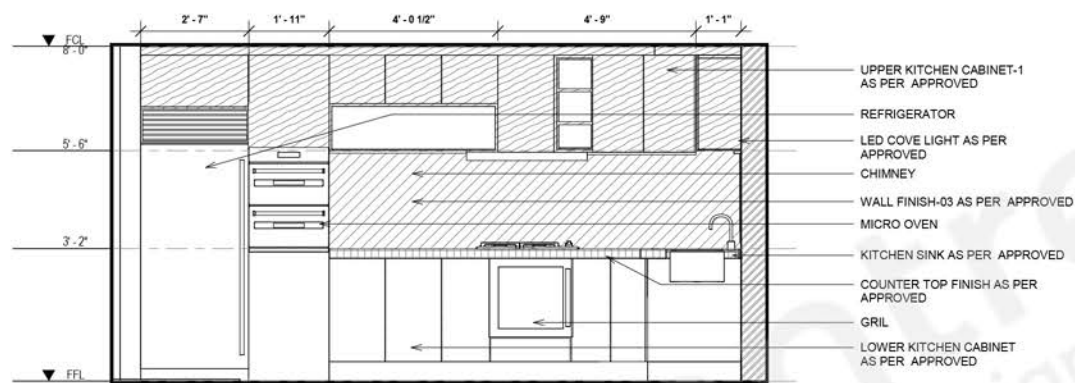

C ELEVATION - C
1: 25

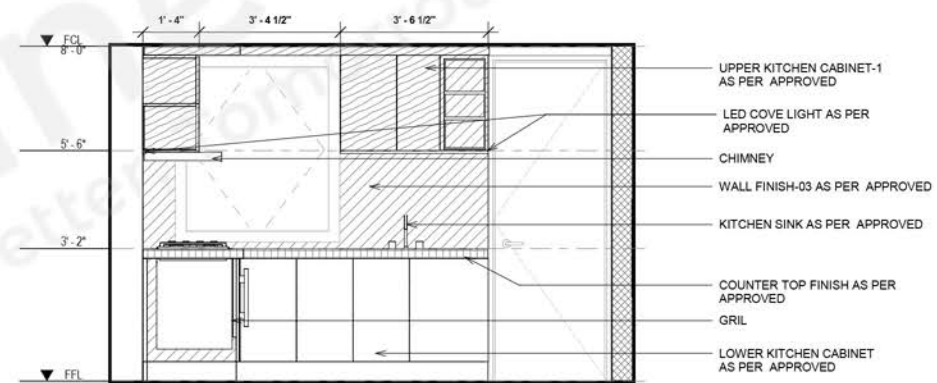

D ELEVATION - D
1: 25

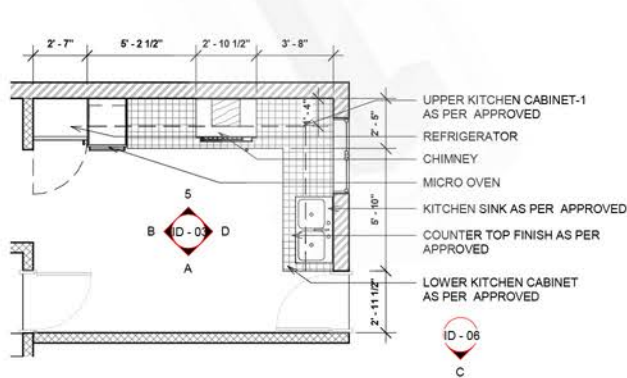

1 KITCHEN - PLAN
1: 50

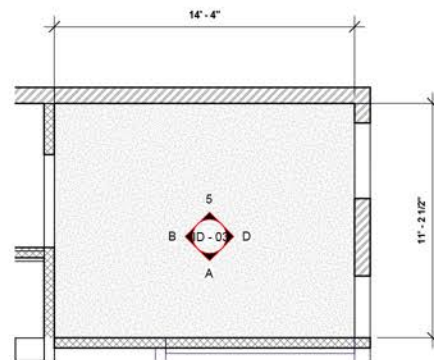

2 KITCHEN - RCP
1: 50



RENDER IMAGE - 01

IMPORTANT NOTES:
CONTRACTOR TO VERIFY ALL DIMENSIONS ON SITE. SHOULD ANY DISCREPANCIES OCCUR CONTACT DESIGNER IMMEDIATELY.
REFER TO FINISHES SCHEDULE FOR FINAL FINISHES.
ALL DIMENSIONS TO BE CHECKED ON SITE PRIOR TO COMMENCEMENT OF WORKS.
DO NOT SCALE OFF DRAWINGS.

FOR APPROVAL
NOT FOR CONSTRUCTION

KEY PLAN

REVISION	DATE	DESCRIPTION	BY

BIM CONSULTANT

CLIENT
DEVELOPMENT MANAGER
CONTRACTOR

PROJECT

DRAWING TITLE
KITCHEN

SCALE	DATE	DRAWN	CHECKED
As indicated @A1			
JOB	DRAWING	REVISION	
ID - 03			

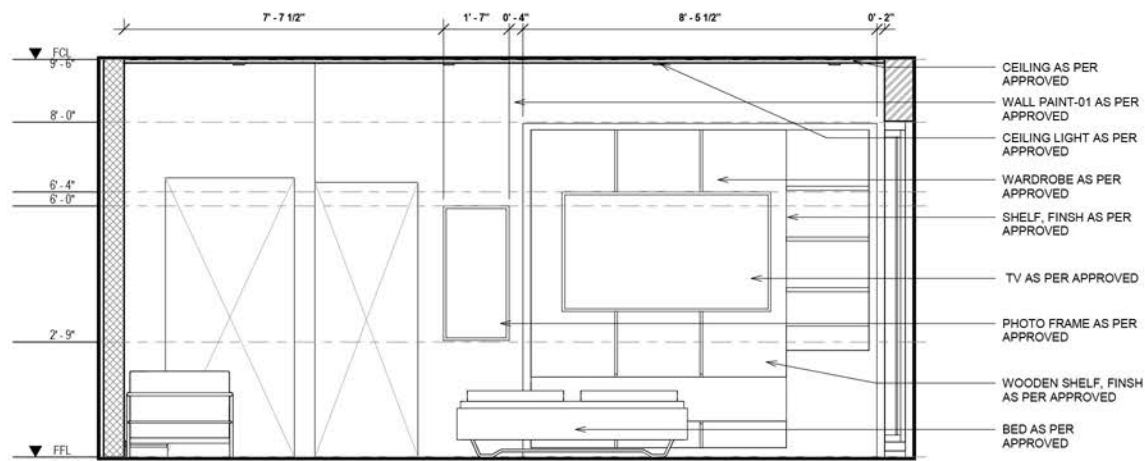

3 ELEVATION - A
1 : 25

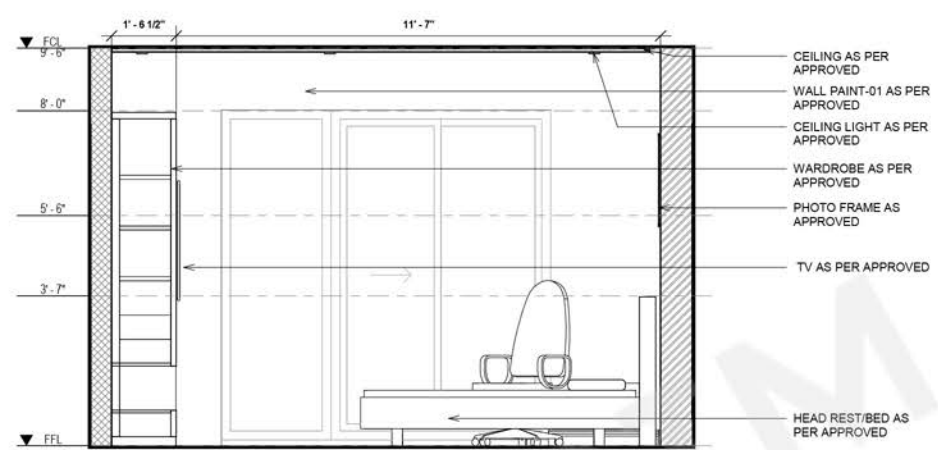

4 ELEVATION - B
1 : 25

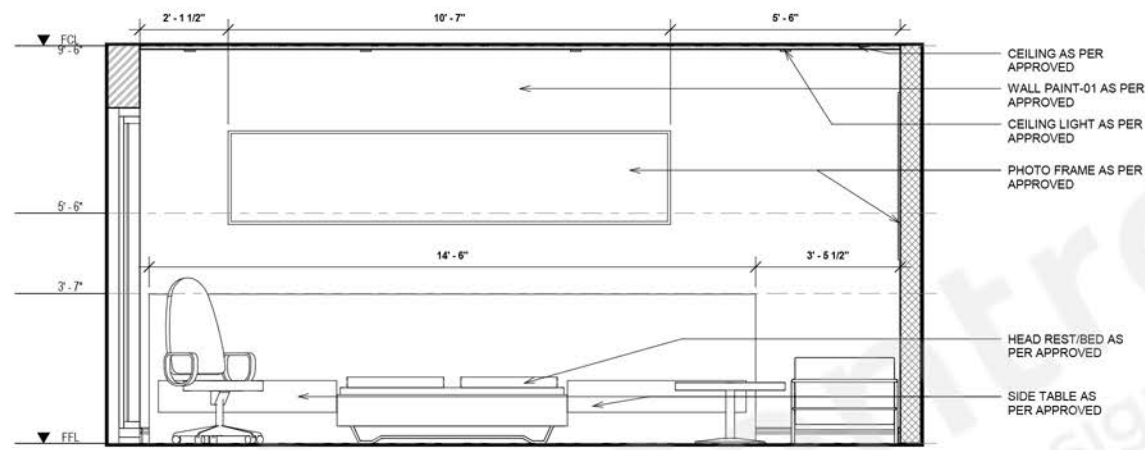

5 ELEVATION - C
1 : 25

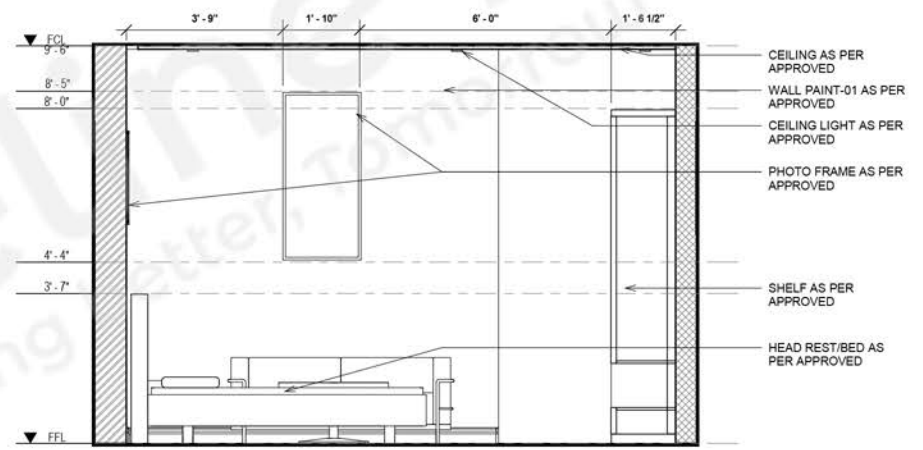

6 ELEVATION - D
1 : 25

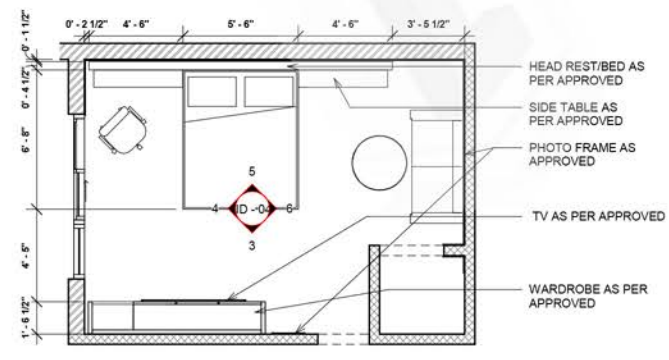

1 MASTER BEDROOM - PLAN
1 : 50

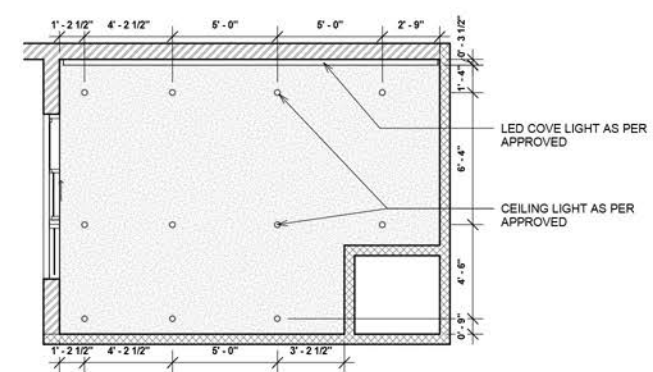

2 MASTER BEDROOM - RCP
1 : 50



RENDER IMAGE - 01

IMPORTANT NOTES:
CONTRACTOR TO VERIFY ALL DIMENSIONS ON SITE. SHOULD ANY DISCREPANCIES OCCUR CONTACT DESIGNER IMMEDIATELY.
REFER TO FINISHES SCHEDULE FOR FINAL FINISHES.
ALL DIMENSIONS TO BE CHECKED ON SITE PRIOR TO COMMENCEMENT OF WORKS.
DO NOT SCALE OFF DRAWINGS.

FOR APPROVAL
NOT FOR CONSTRUCTION

KEY PLAN

REVISION	DATE	DESCRIPTION	BY

BIM CONSULTANT

CLIENT

DEVELOPMENT MANAGER

CONTRACTOR

PROJECT

DRAWING TITLE
MASTER BEDROOM

SCALE	DATE	DRAWN	CHECKED
As indicated @A1			
JOB	DRAWING	REVISION	
	ID - 04		

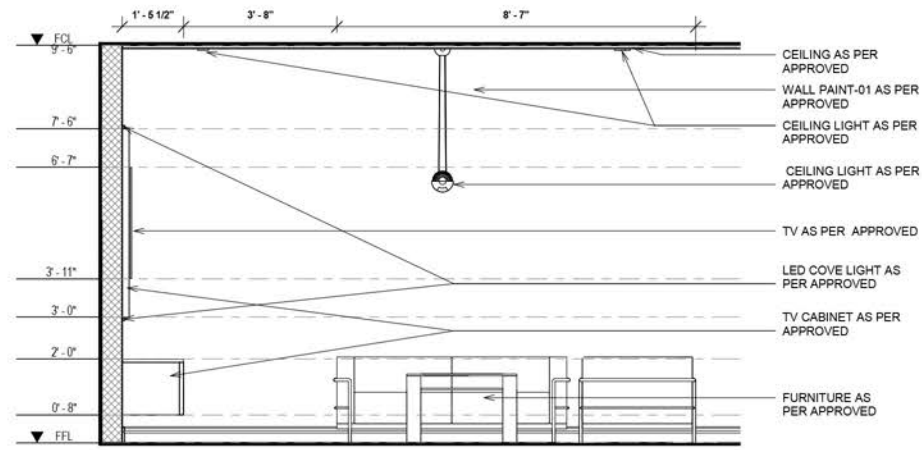

A ELEVATION - A
1 : 25

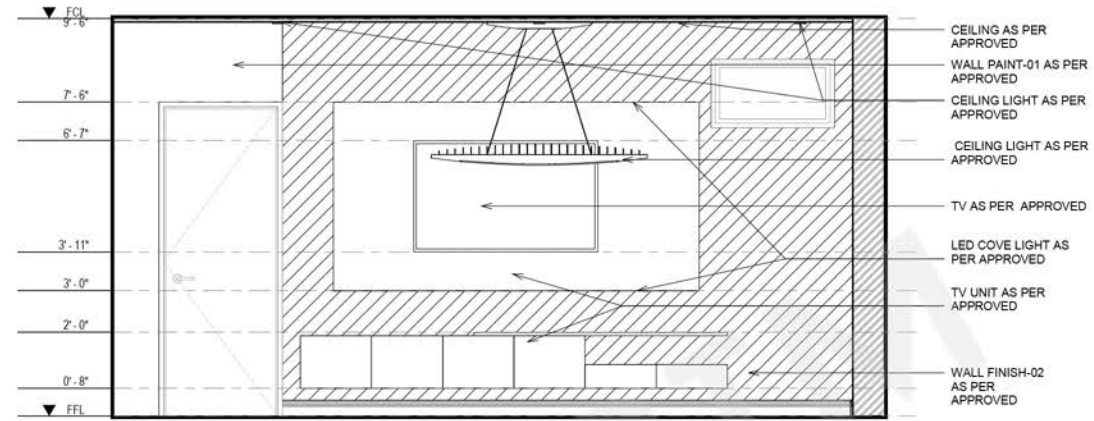

B ELEVATION - B
1 : 25

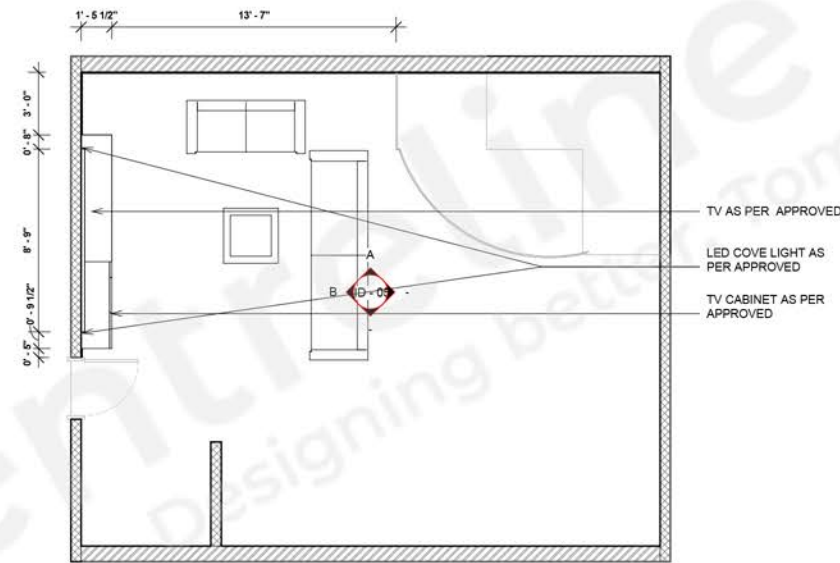

1 SECOND FLOOR LIVING - PLAN
1 : 50

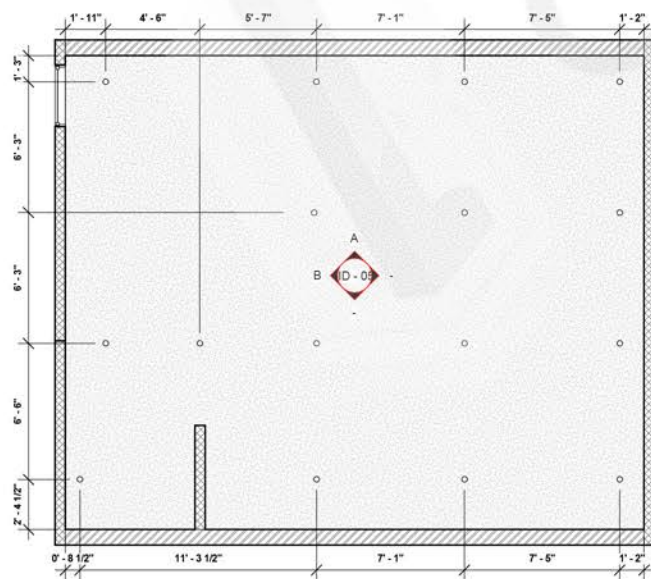

2 SECOND FLOOR LIVING - RCP
1 : 50



RENDER IMAGE - 01

IMPORTANT NOTES:
 CONTRACTOR TO VERIFY ALL DIMENSIONS ON SITE. SHOULD ANY DISCREPANCIES OCCUR CONTACT DESIGNER IMMEDIATELY.
 REFER TO FINISHES SCHEDULE FOR FINAL FINISHES.
 ALL DIMENSIONS TO BE CHECKED ON SITE PRIOR TO COMMENCEMENT OF WORKS.
 DO NOT SCALE OFF DRAWINGS.

FOR APPROVAL
 NOT FOR CONSTRUCTION

KEY PLAN

REVISION	DATE	DESCRIPTION	BY

BIM CONSULTANT

CLIENT

DEVELOPMENT MANAGER

CONTRACTOR

PROJECT

DRAWING TITLE
SECOND FLOOR LIVING

SCALE	DATE	DRAWN	CHECKED
As indicated @A1			
JOB	DRAWING	REVISION	
	ID - 05		

IMPORTANT NOTES:
 CONTRACTOR TO VERIFY ALL DIMENSIONS ON SITE. SHOULD ANY DISCREPANCIES OCCUR CONTACT DESIGNER IMMEDIATELY.
 REFER TO FINISHES SCHEDULE FOR FINAL FINISHES.
 ALL DIMENSIONS TO BE CHECKED ON SITE PRIOR TO COMMENCEMENT OF WORKS.
 DO NOT SCALE OFF DRAWINGS.

FOR APPROVAL
 NOT FOR CONSTRUCTION

KEY PLAN

REVISION	DATE	DESCRIPTION	BY

BIM CONSULTANT

CLIENT

DEVELOPMENT MANAGER

CONTRACTOR

PROJECT

DRAWING TITLE
LIVING

SCALE	DATE	DRAWN	CHECKED
As indicated @A1			
JOB	DRAWING	REVISION	
	ID - 06		

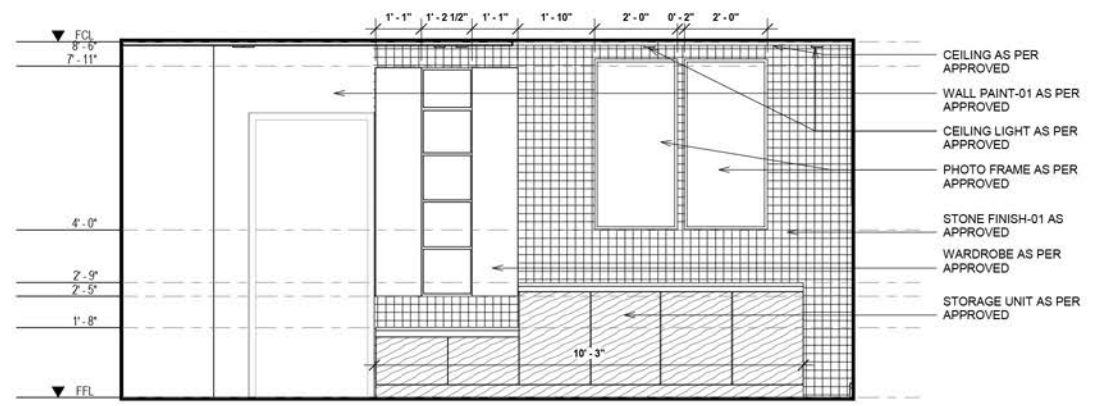

A ELEVATION - A
 1 : 25

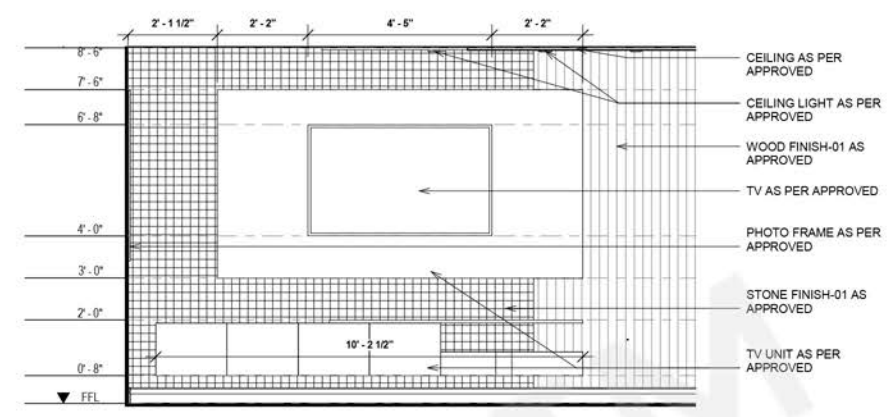

B ELEVATION - B
 1 : 25

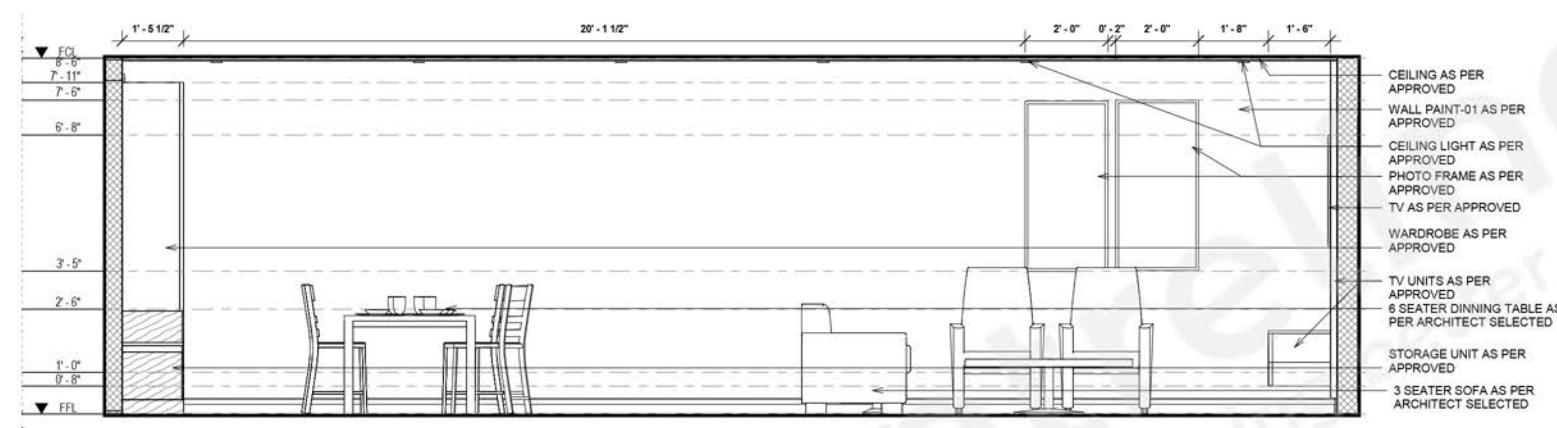

C ELEVATION - C
 1 : 25



RENDER IMAGE - 01

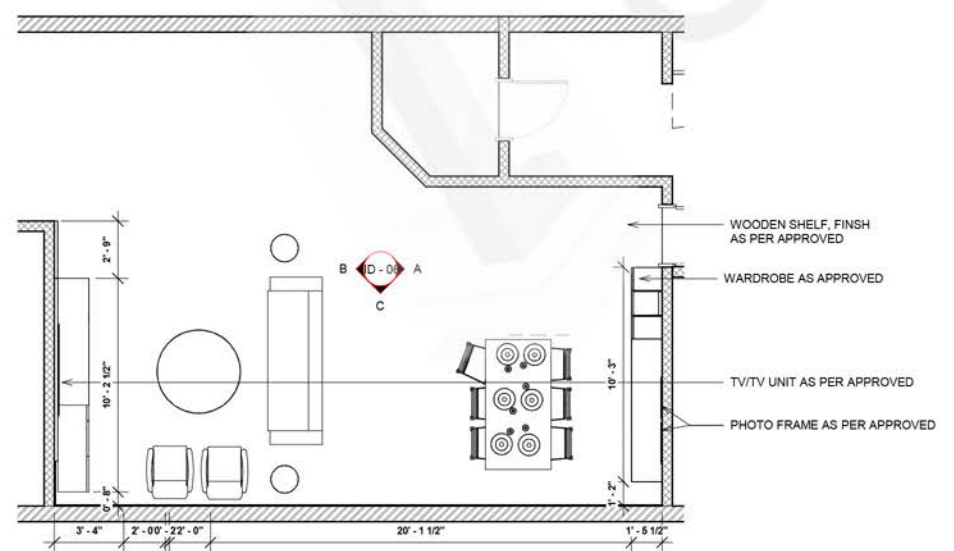

4 LIVING - PLAN
 1 : 50

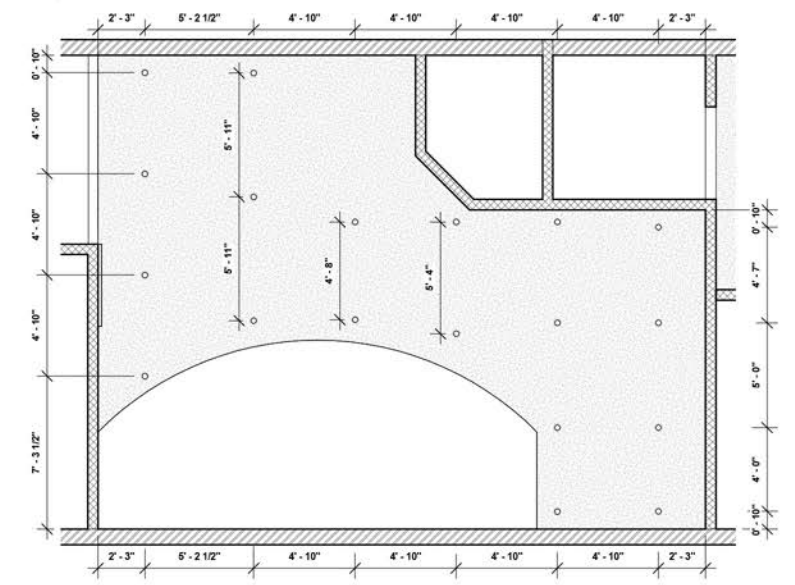

5 LIVING - RCP
 1 : 50



RENDER IMAGE - 02

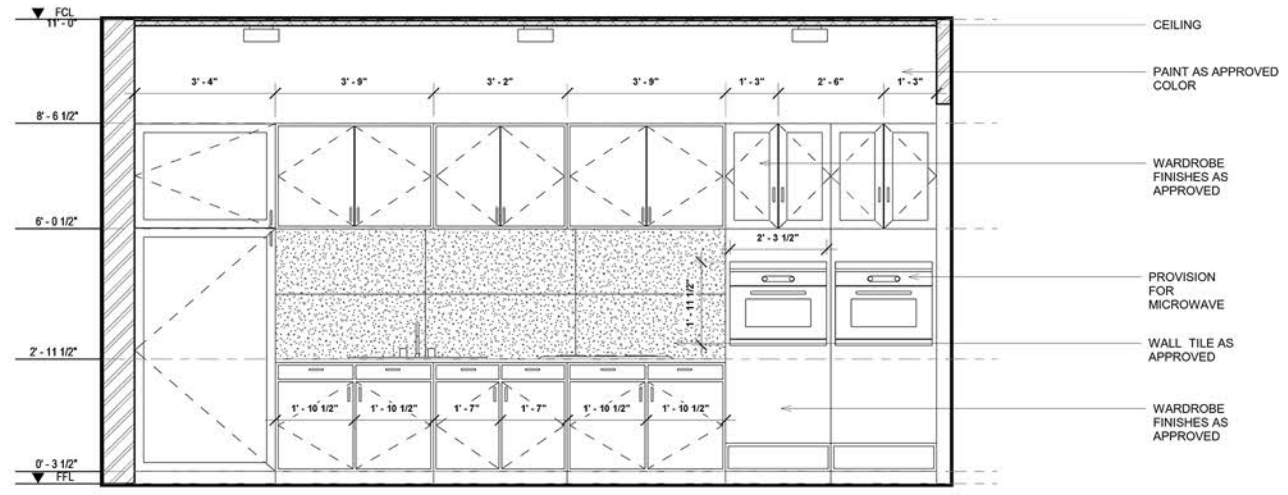

A ELEVATION - A
1 : 25

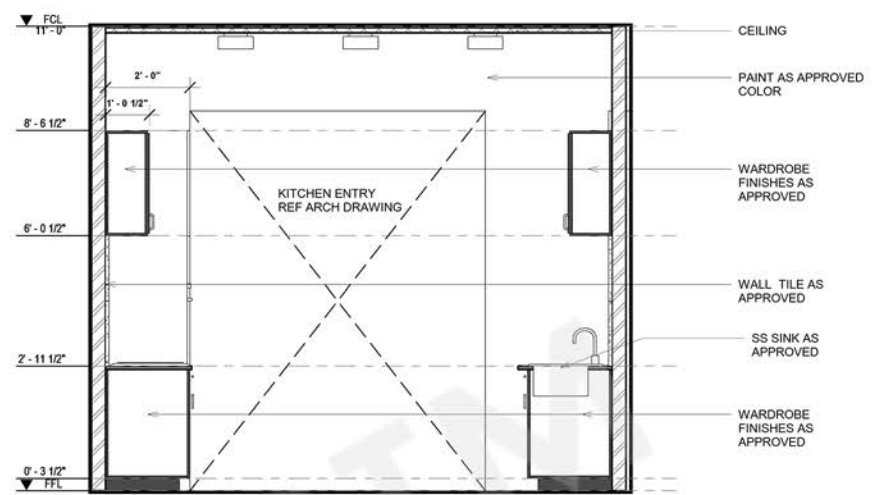

B ELEVATION - B
1 : 25

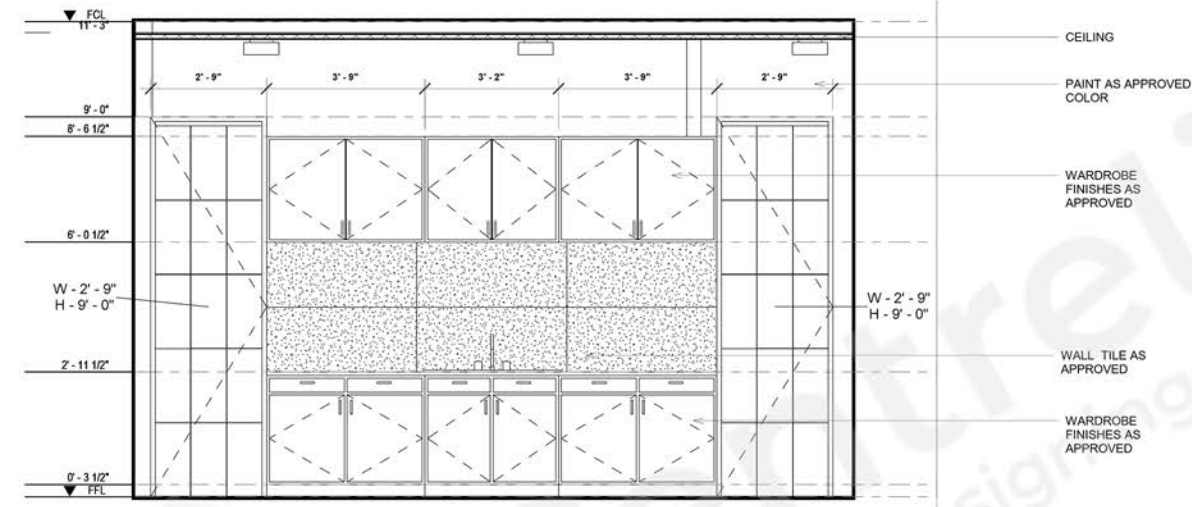

C ELEVATION - C
1 : 25

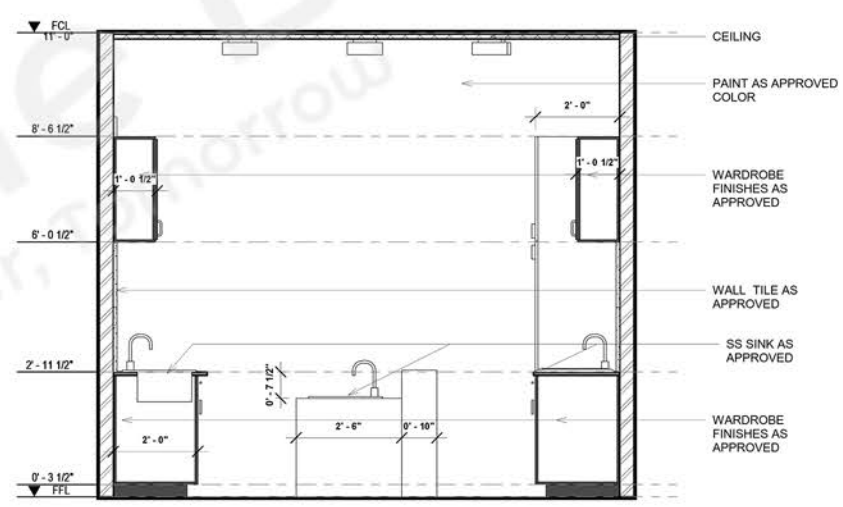

D ELEVATION - D
1 : 25

IMPORTANT NOTES:
CONTRACTOR TO VERIFY ALL DIMENSIONS ON SITE. SHOULD ANY DISCREPANCIES OCCUR CONTACT DESIGNER IMMEDIATELY.
REFER TO FINISHES SCHEDULE FOR FINAL FINISHES.
ALL DIMENSIONS TO BE CHECKED ON SITE PRIOR TO COMMENCEMENT OF WORKS.
DO NOT SCALE OFF DRAWINGS.

FOR APPROVAL
NOT FOR CONSTRUCTION

KEY PLAN

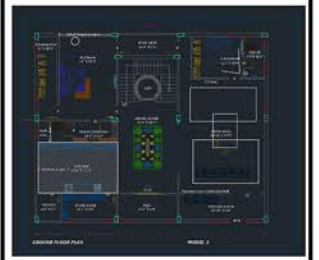

REVISION	DATE	DESCRIPTION	BY

BIM CONSULTANT

CLIENT

DEVELOPMENT MANAGER

CONTRACTOR

PROJECT

DRAWING TITLE
GROUND FLOOR KITCHEN

SCALE	DATE	DRAWN	CHECKED
As Indicated @A1			
JOB	DRAWING	REVISION	
	ID - 2		

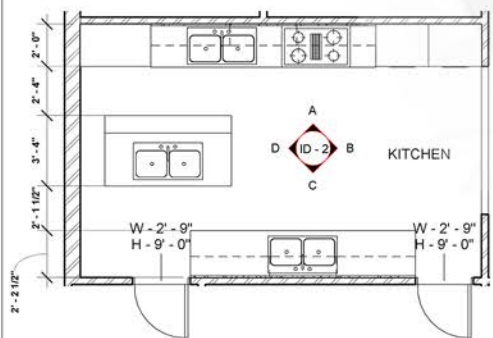

1 KITCHEN - PLAN
1 : 50

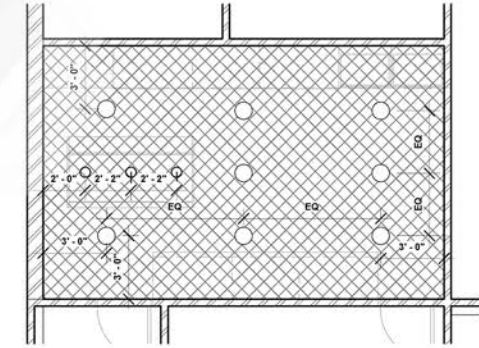

2 KITCHEN - RCP
1 : 50



RENDER IMAGE - 01



RENDER IMAGE - 02

ELECTRICAL NOTES:
REFER TO ELECTRICAL CONSULTANTS FOR DOCUMENTATION FOR LIGHTING, POWER, VOICE AND DATA PROVISIONS.

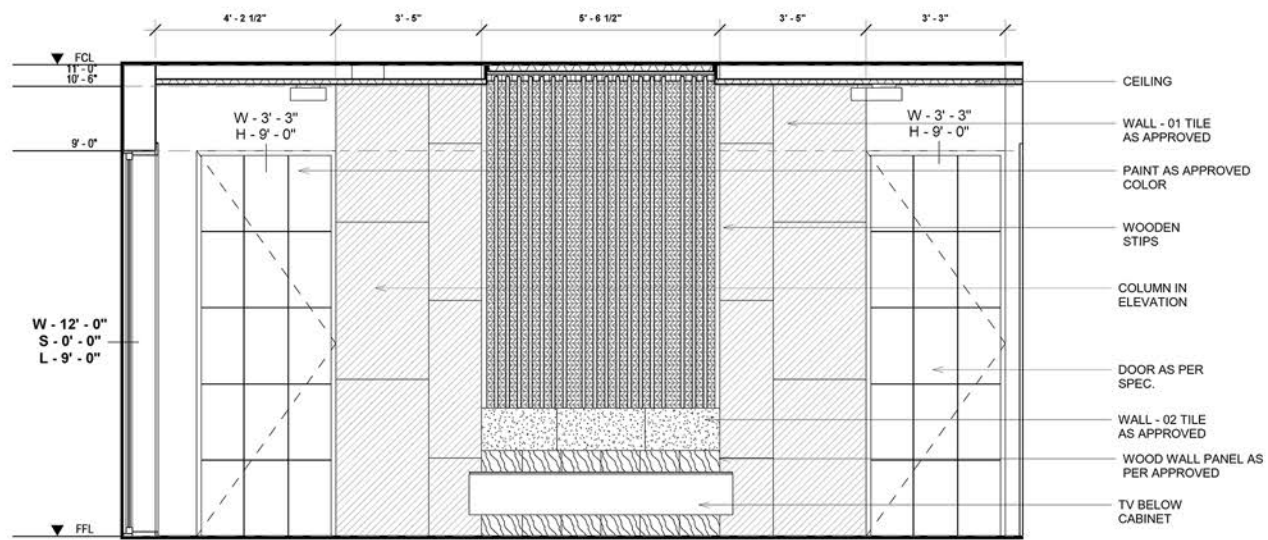

A Elevation - A
1 : 25

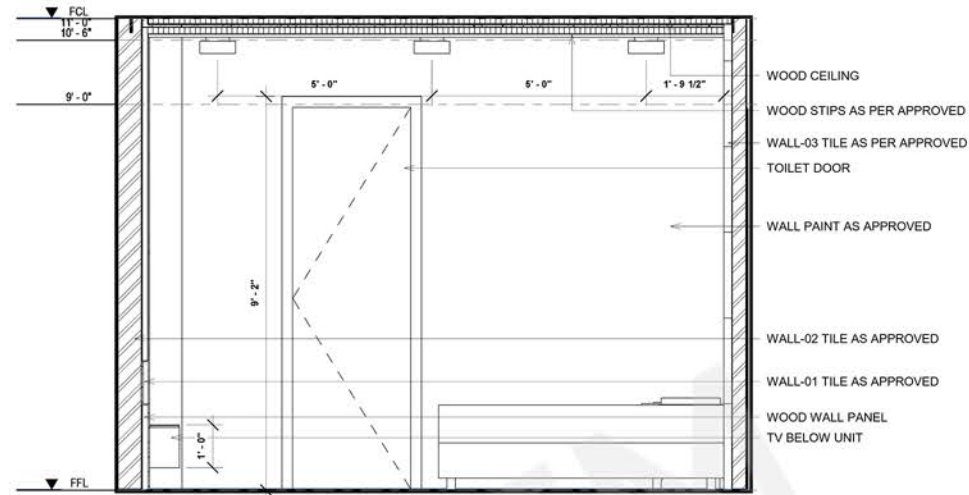

B Elevation - B
1 : 25

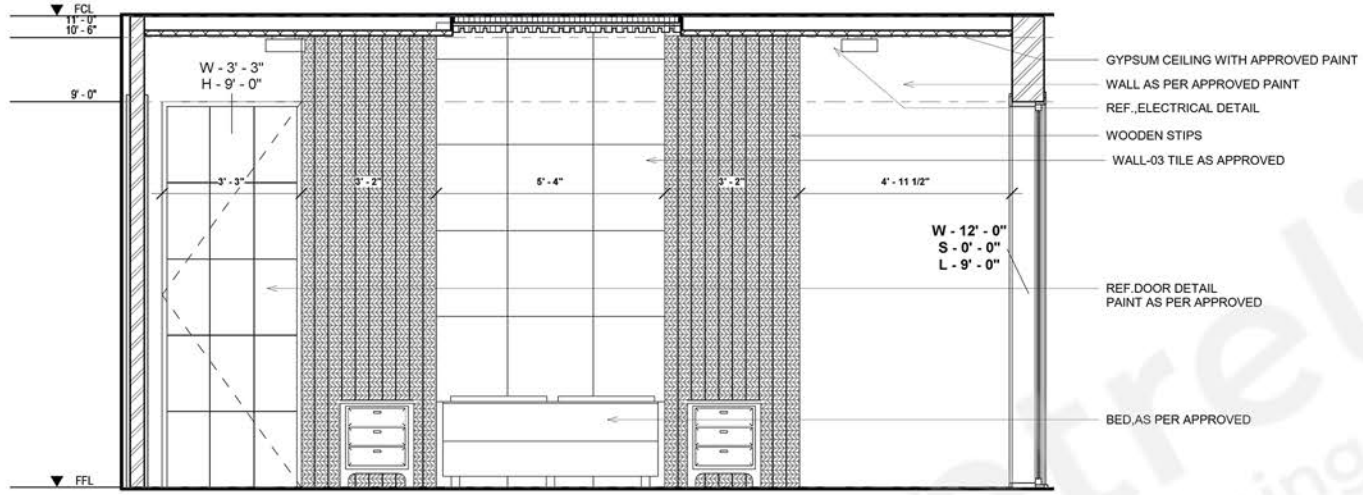

C Elevation - C
1 : 25

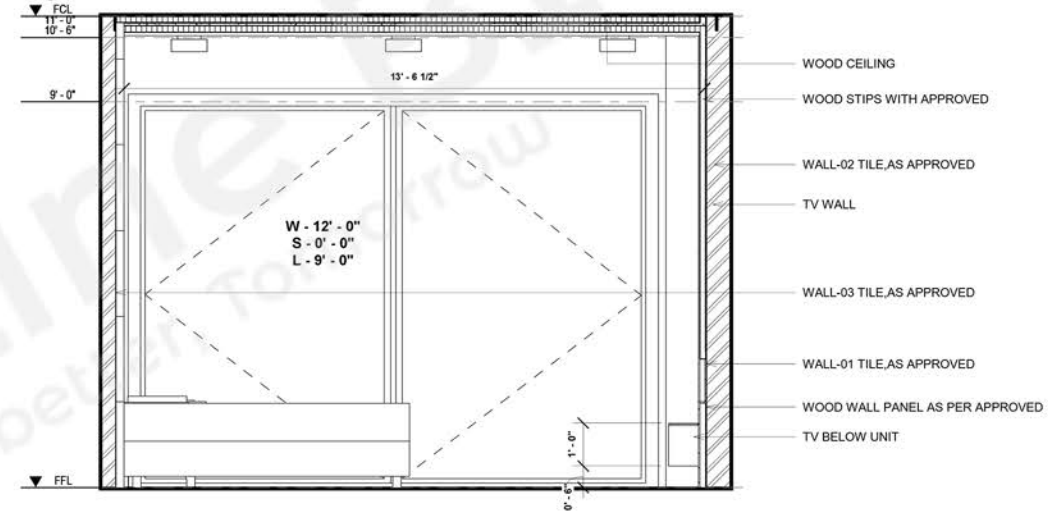

D Elevation - D
1 : 25

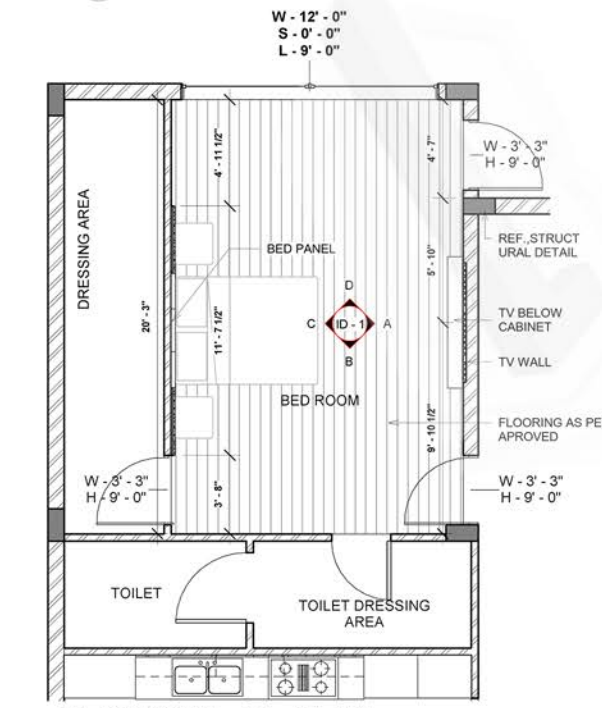

1 BEDROOM - 01 - PLAN
1 : 50



2 BEDROOM - 01 - RCP
1 : 50



RENDER IMAGE - 01



RENDER IMAGE - 02

ELECTRICAL NOTES:
REFER TO ELECTRICAL CONSULTANTS FOR DOCUMENTATION FOR LIGHTING, POWER, VOICE AND DATA PROVISIONS.

IMPORTANT NOTES:
CONTRACTOR TO VERIFY ALL DIMENSIONS ON SITE. SHOULD ANY DISCREPANCIES OCCUR CONTACT DESIGNER IMMEDIATELY.
REFER TO FINISHES SCHEDULE FOR FINAL FINISHES.
ALL DIMENSIONS TO BE CHECKED ON SITE PRIOR TO COMMENCEMENT OF WORKS.
DO NOT SCALE OFF DRAWINGS.

FOR APPROVAL
NOT FOR CONSTRUCTION

KEY PLAN

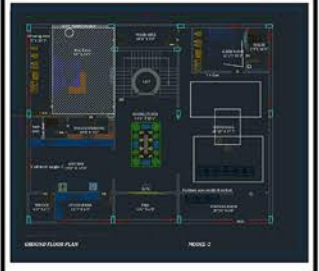

REVISION	DATE	DESCRIPTION	BY
1	20-12-2019	ISSUED FOR APPROVAL	

BIM CONSULTANT

CLIENT

DEVELOPMENT MANAGER

CONTRACTOR

PROJECT

DRAWING TITLE
**GROUND FLOOR
BEDROOM - 01**

SCALE	DATE	DRAWN	CHECKED
As indicated @A1			
JOB	DRAWING	REVISION	
	ID - 1	1	

IMPORTANT
 CONTRACTOR TO VERIFY ALL DIMENSIONS ON SITE. SHOULD ANY DISCREPANCIES OCCUR CONTACT DESIGNER IMMEDIATELY.
 REFER TO FINISHES SCHEDULE FOR FINAL FINISHES.
 ALL DIMENSIONS TO BE CHECKED ON SITE PRIOR TO COMMENCEMENT OF WORKS.
 DO NOT SCALE OFF DRAWINGS.

FOR APPROVAL
 NOT FOR CONSTRUCTION

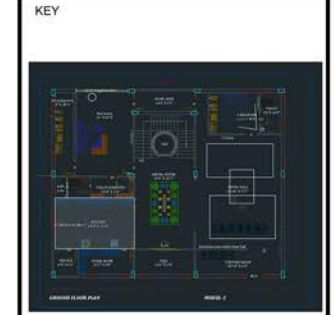

REVISION	DATE	DESCRIPTION	BY

BIM

CLIENT

DEVELOPMENT

CONTRACTOR

PROJECT

DRAWING
DINNING

SCALE	DAT	DRAW	CHECKED
As Indicated @A1			
JOB	DRAWING ID - 3		REVISION

ELECTRICAL NOTES:
 REFER TO ELECTRICAL CONSULTANTS FOR DOCUMENTATION FOR LIGHTING, POWER, VOICE AND DATA PROVISIONS.

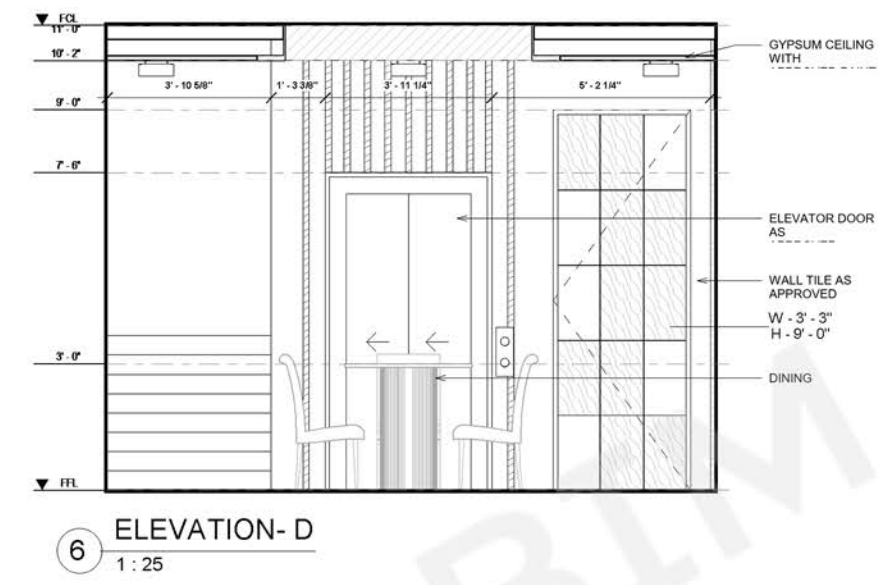

6 ELEVATION-D
 1 : 25

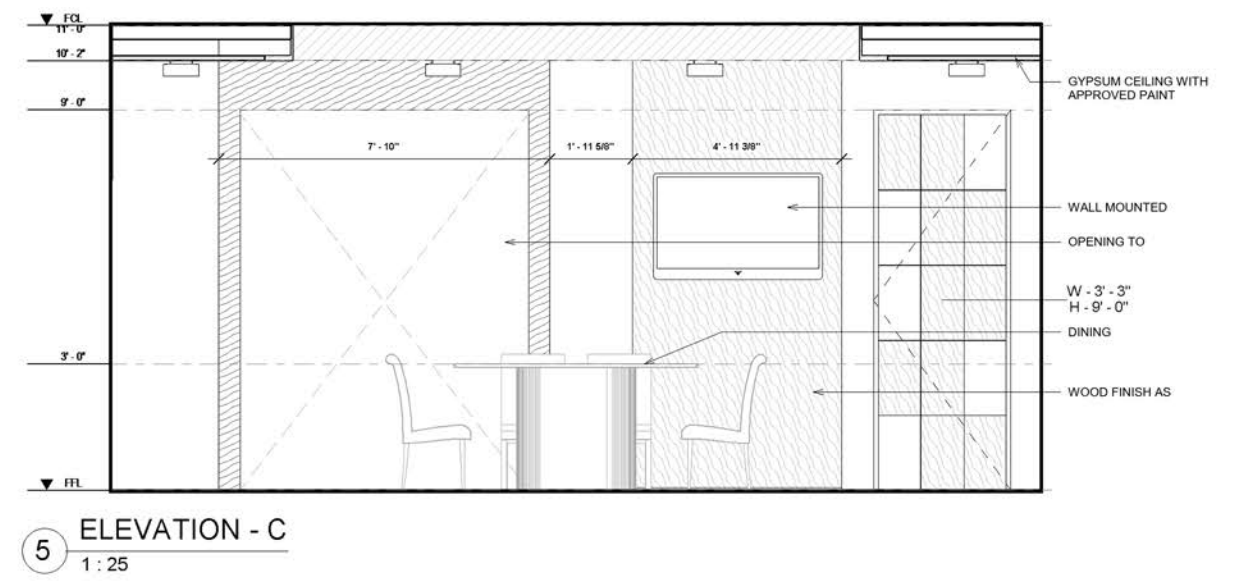

5 ELEVATION - C
 1 : 25

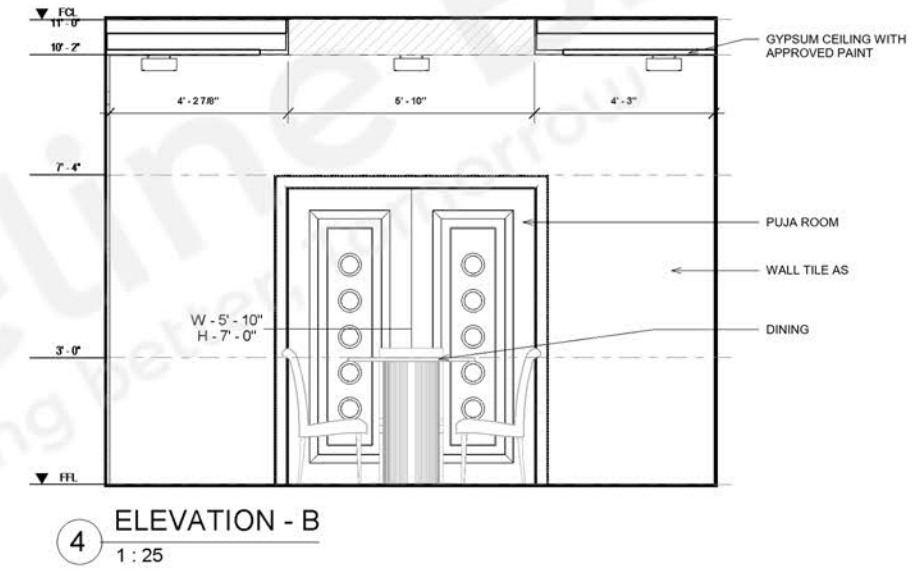

4 ELEVATION - B
 1 : 25

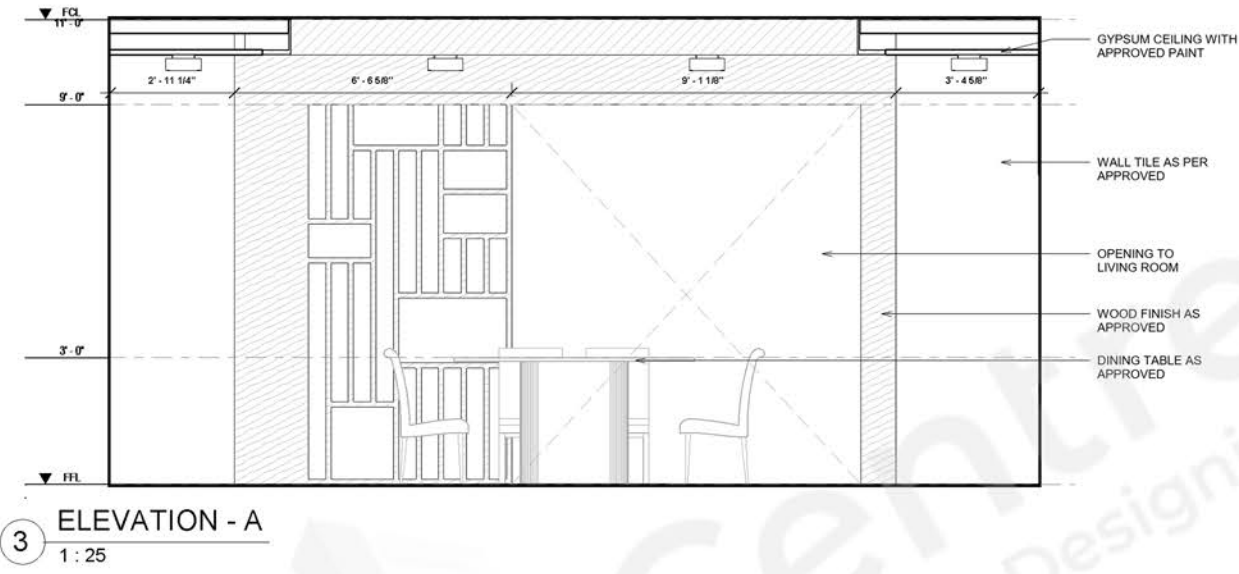

3 ELEVATION - A
 1 : 25

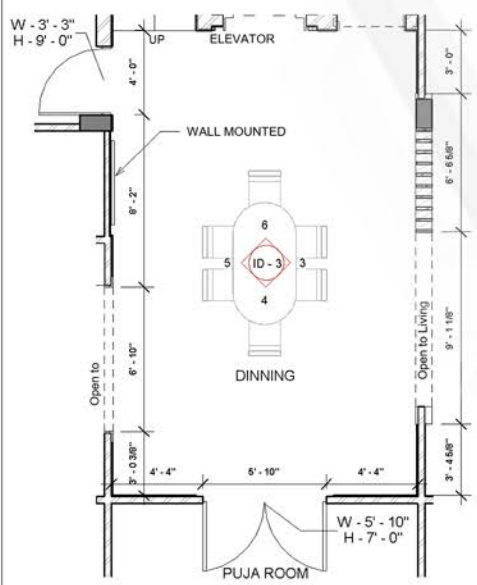

1 DINNING - PLAN
 1 : 50

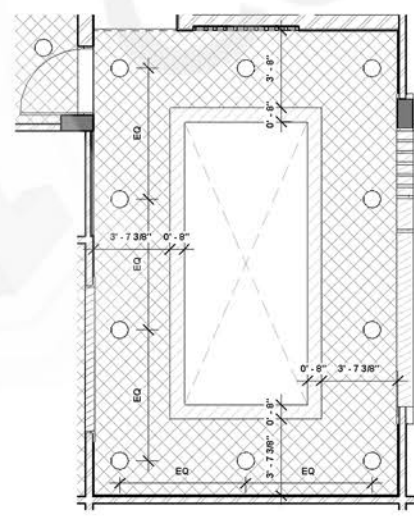

2 DINNING - RCP
 1 : 50

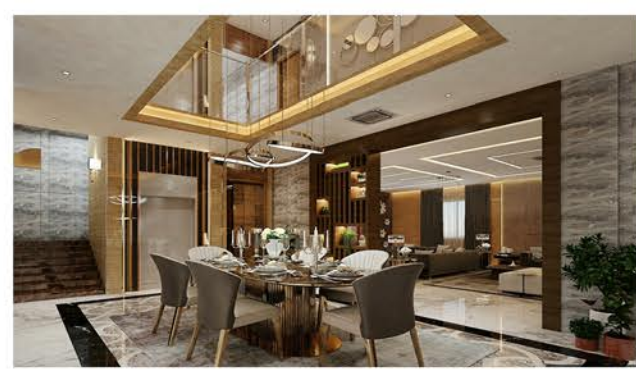

RENDER IMAGE - 01

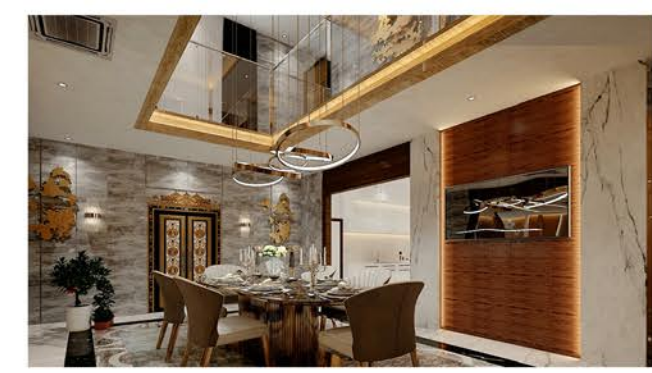

RENDER IMAGE - 02

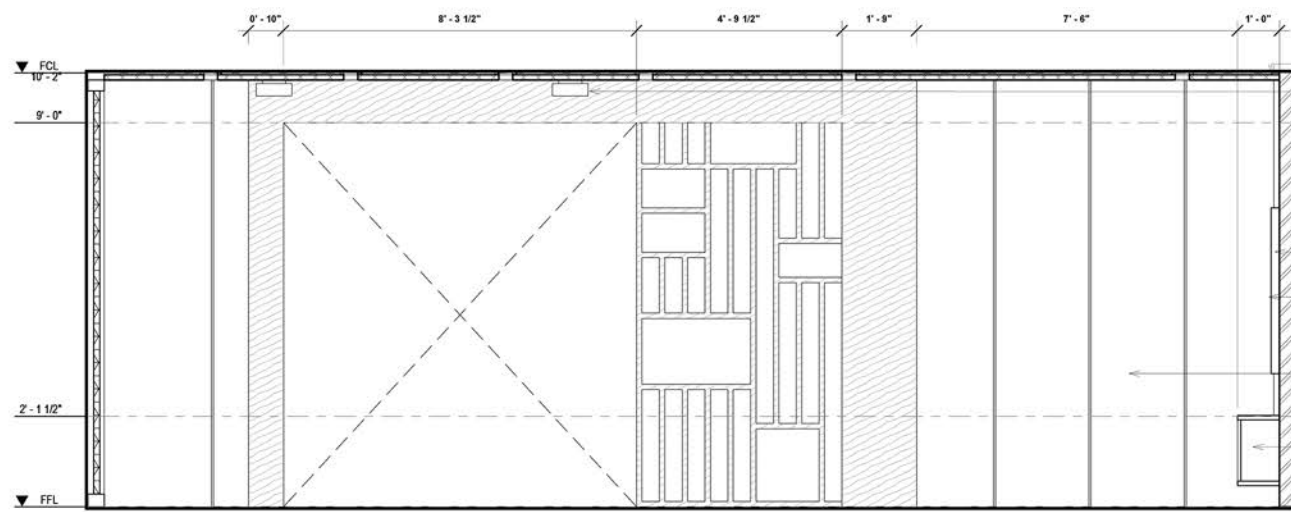

A ELEVATION A
1 : 25

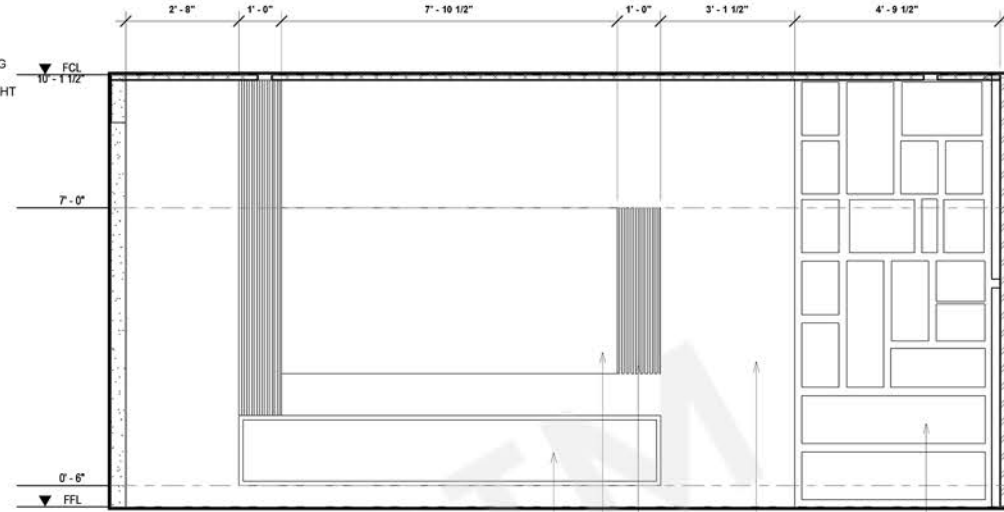

B ELEVATION B
1 : 25

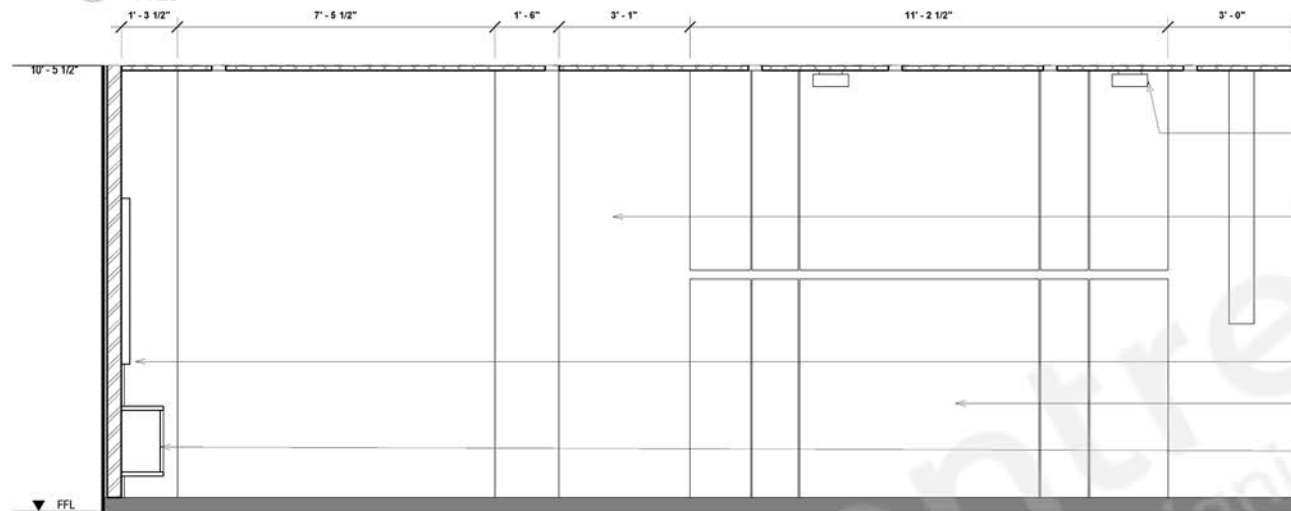

C ELEVATION C
1 : 25

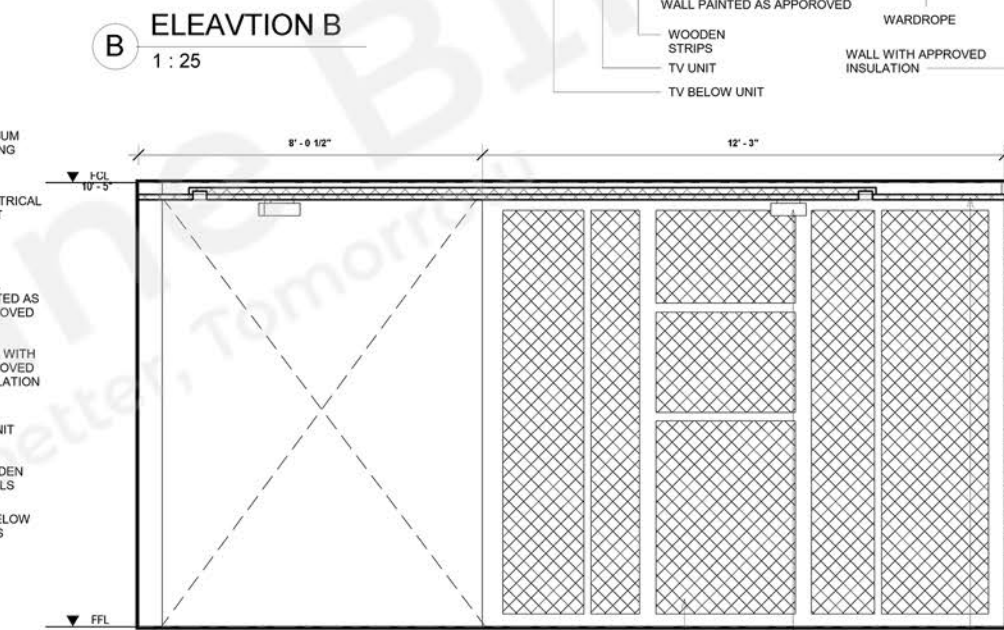

D ELEVATION D
1 : 25

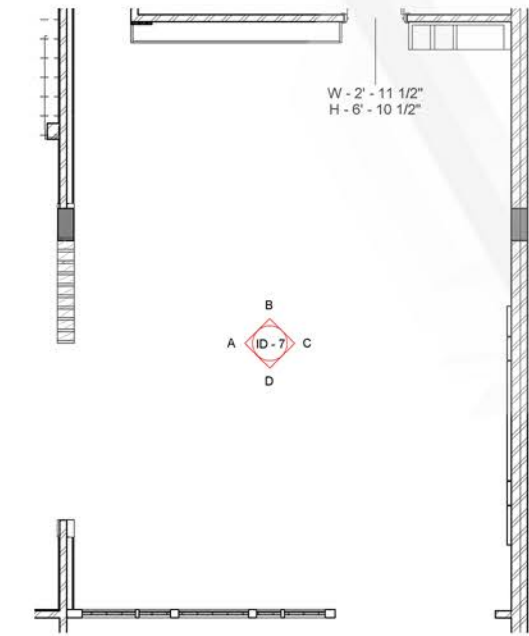

1 LIVING ROOM PLAN
1 : 50

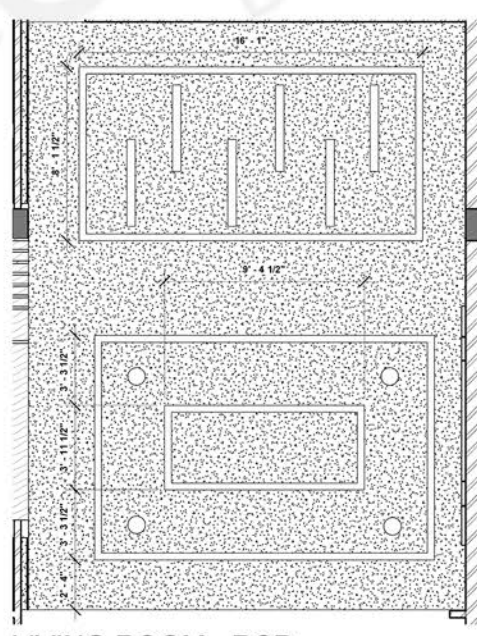

2 LIVING ROOM - RCP
1 : 50



RENDER IMAGE - 01

IMPORTANT NOTES:
CONTRACTOR TO VERIFY ALL DIMENSIONS ON SITE. SHOULD ANY DISCREPANCIES OCCUR CONTACT DESIGNER IMMEDIATELY.
REFER TO FINISHES SCHEDULE FOR FINAL GYPSUM CEILING
ALL DIMENSIONS TO BE CHECKED ON SITE PRIOR TO COMMENCEMENT OF WORKS.
DO NOT SCALE OFF DRAWINGS.

FOR APPROVAL
NOT FOR CONSTRUCTION

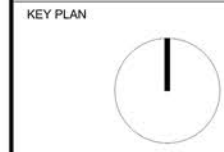

REVISION	DATE	DESCRIPTION	BY

REVISION	DATE	DESCRIPTION	BY

BIM CONSULTANT

CLIENT

DEVELOPMENT MANAGER

CONTRACTOR

PROJECT

DRAWING TITLE
LIVING ROOM

SCALE	DATE	DRAWN	CHECKED
As indicated @A1			
JOB	DRAWING	REVISION	
	ID - 7		

IMPORTANT NOTES:
 CONTRACTOR TO VERIFY ALL DIMENSIONS ON SITE. SHOULD ANY DISCREPANCIES OCCUR CONTACT DESIGNER IMMEDIATELY.
 REFER TO FINISHES SCHEDULE FOR FINAL FINISHES.
 ALL DIMENSIONS TO BE CHECKED ON SITE PRIOR TO COMMENCEMENT OF WORKS.
 DO NOT SCALE OFF DRAWINGS.

FOR APPROVAL
 NOT FOR CONSTRUCTION

KEY PLAN

REVISION	DATE	DESCRIPTION	BY
1	20-12-2019	ISSUED FOR APPROVAL	

BIM CONSULTANT

CLIENT

DEVELOPMENT MANAGER

CONTRACTOR

PROJECT

DRAWING TITLE
DRESSING ROOM

SCALE	DATE	DRAWN	CHECKED

JOB	DRAWING	REVISION
	ID - 4	1

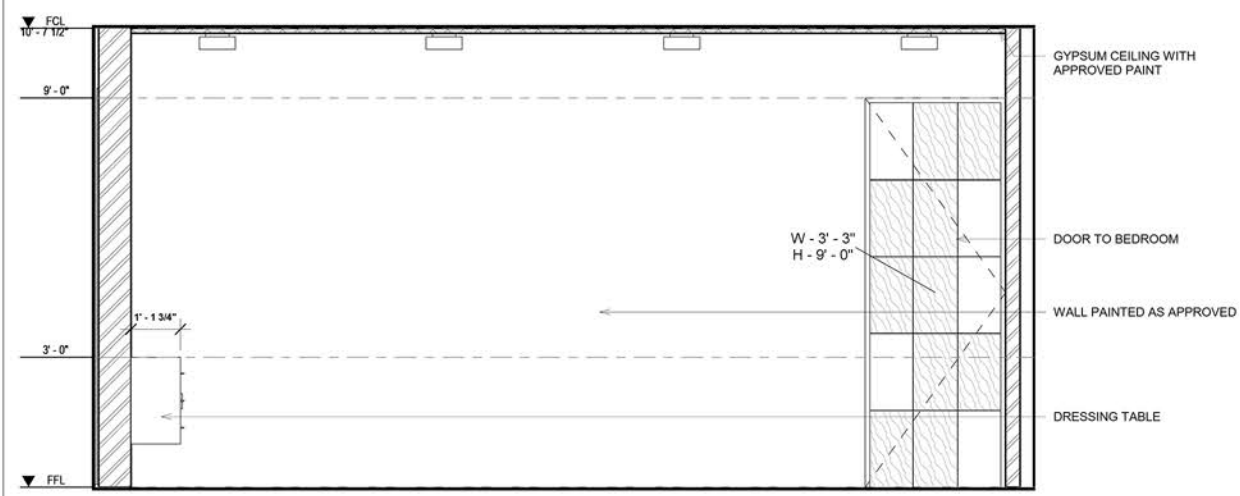

A Elevation A
 1 : 25

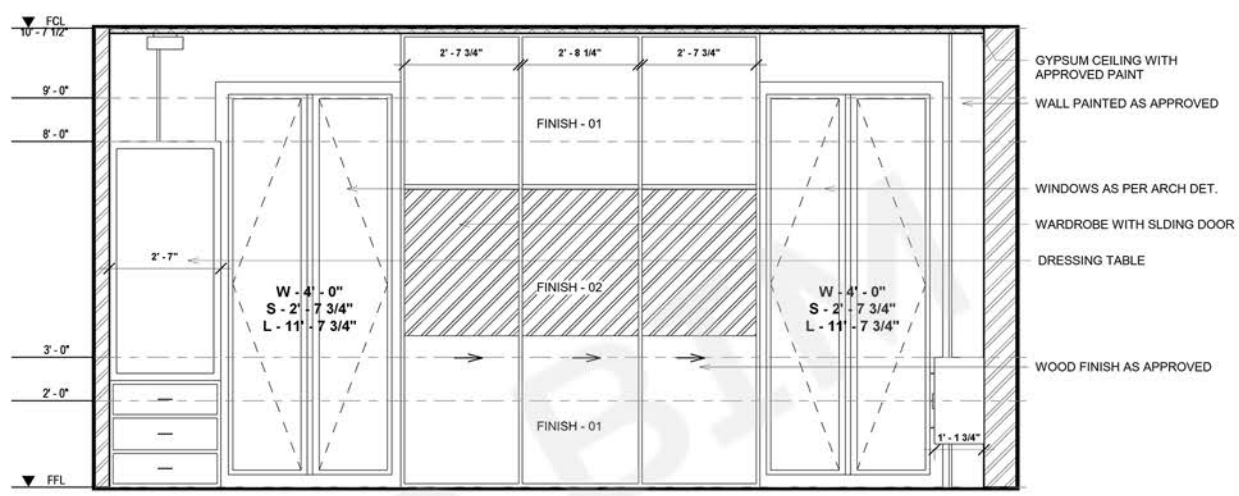

B Elevation B
 1 : 25

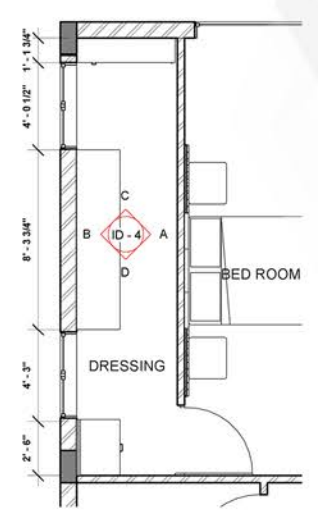

1 DRESSING - PLAN
 1 : 50

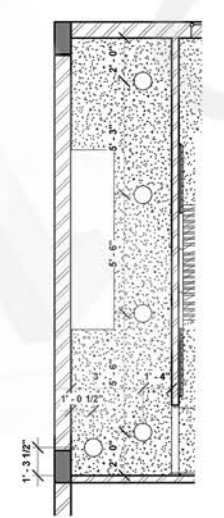

2 DRESSING - RCP
 1 : 50

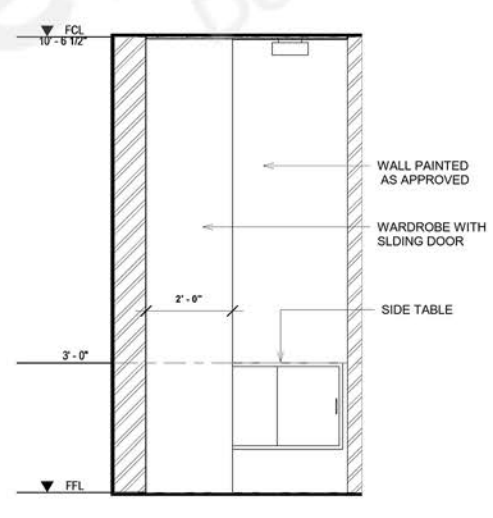

C Elevation C
 1 : 25

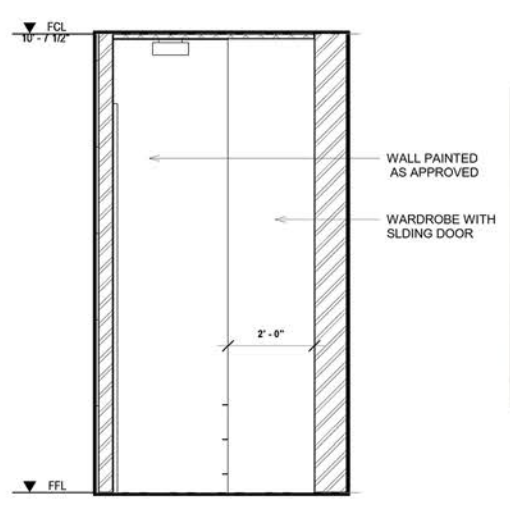

D Elevation D
 1 : 25



RENDER IMAGE - 01

ELECTRICAL NOTES:
 REFER TO ELECTRICAL CONSULTANTS FOR DOCUMENTATION FOR LIGHTING, POWER, VOICE AND DATA PROVISIONS.

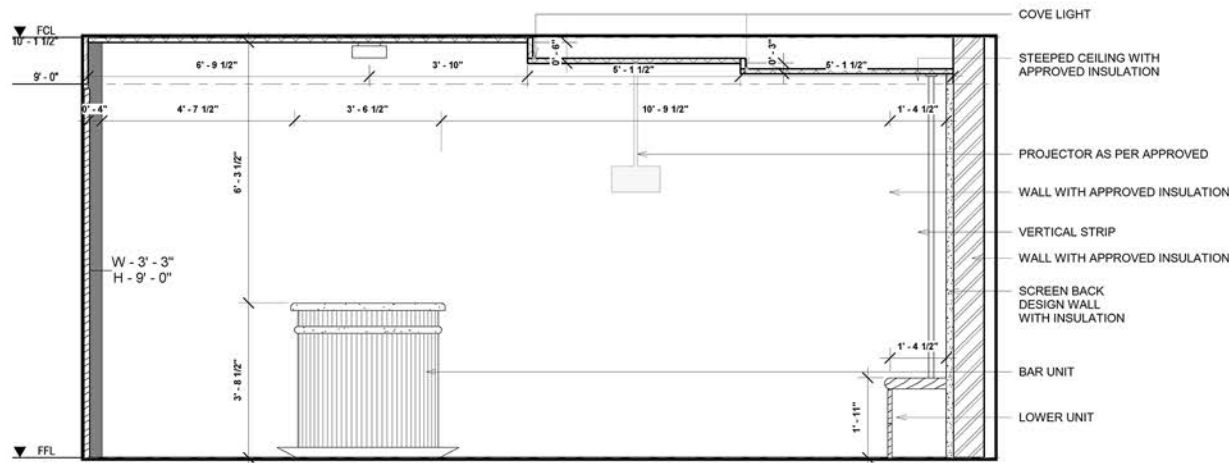

A HOME THEATRE ELEVATION-A
1: 25

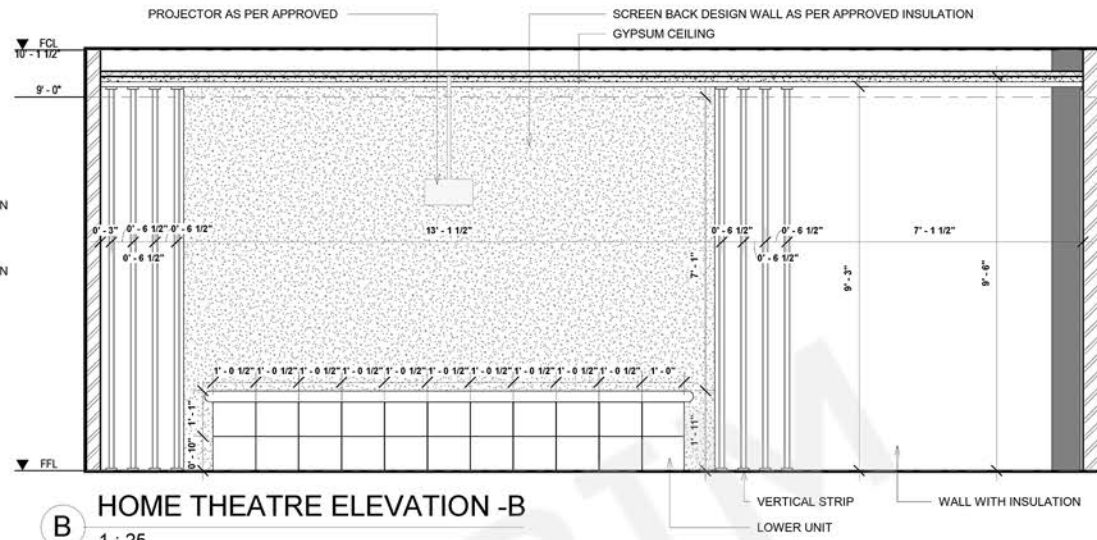

B HOME THEATRE ELEVATION-B
1: 25

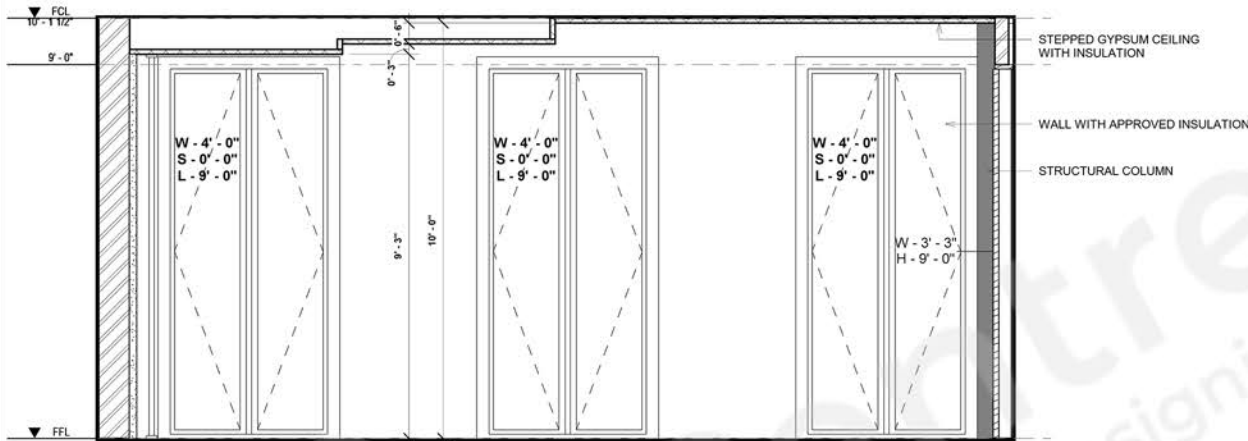

C HOME THEATRE ELEVATION-C
1: 25

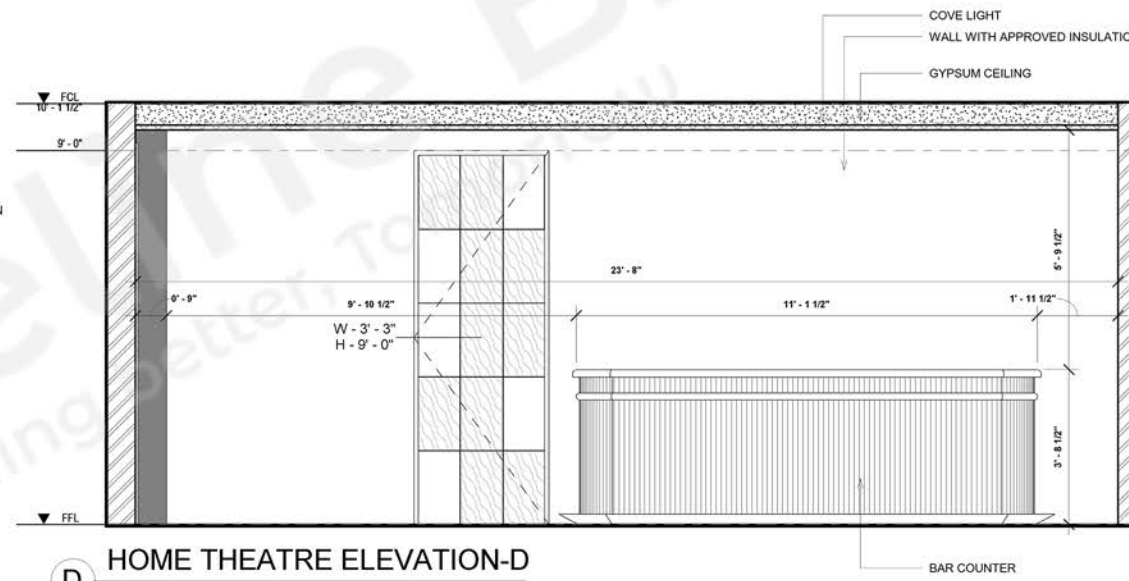

D HOME THEATRE ELEVATION-D
1: 25

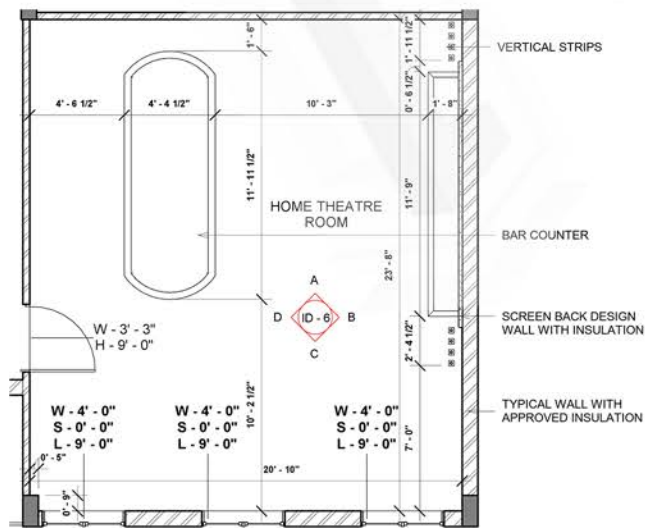

1 HOME THEATRE - PLAN VIEW
1: 50

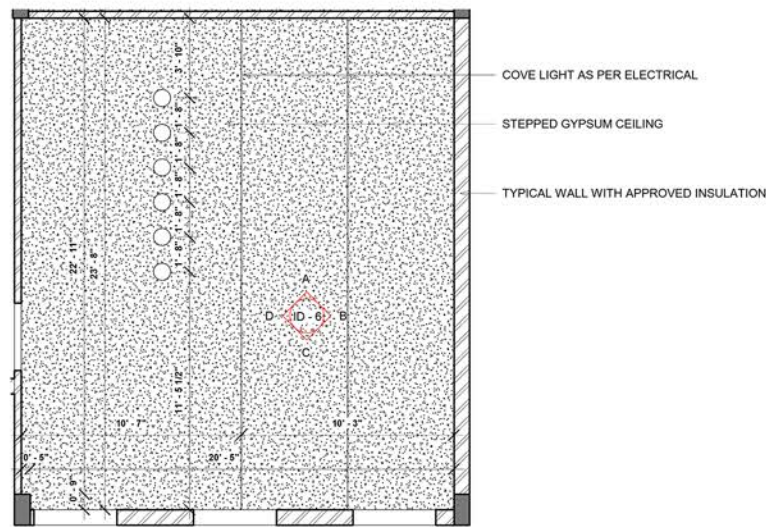

2 HOME THEATRE-RCP
1: 50



IMPORTANT NOTES:
CONTRACTOR TO VERIFY ALL DIMENSIONS ON SITE. SHOULD ANY DISCREPANCIES OCCUR CONTACT DESIGNER IMMEDIATELY.
REFER TO FINISHES SCHEDULE FOR FINAL FINISHES.
ALL DIMENSIONS TO BE CHECKED ON SITE PRIOR TO COMMENCEMENT OF WORKS.
DO NOT SCALE OFF DRAWINGS.

FOR APPROVAL
NOT FOR CONSTRUCTION

KEY PLAN

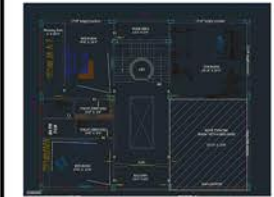

REVISION	DATE	DESCRIPTION	BY

BIM CONSULTANT

CLIENT

DEVELOPMENT MANAGER

CONTRACTOR

PROJECT

DRAWING TITLE
HOME THEATRE

SCALE	DATE	DRAWN	CHECKED

JOB	DRAWING	REVISION

ELECTRICAL NOTES:
REFER TO ELECTRICAL CONSULTANTS FOR DOCUMENTATION FOR LIGHTING, POWER, VOICE AND DATA PROVISIONS.

IMPORTANT NOTES:
 CONTRACTOR TO VERIFY ALL DIMENSIONS ON SITE. SHOULD ANY DISCREPANCIES OCCUR CONTACT DESIGNER IMMEDIATELY.
 REFER TO FINISHES SCHEDULE FOR FINAL FINISHES.
 ALL DIMENSIONS TO BE CHECKED ON SITE PRIOR TO COMMENCEMENT OF WORKS.
 DO NOT SCALE OFF DRAWINGS.

FOR APPROVAL
 NOT FOR CONSTRUCTION

KEY PLAN



REVISION	DATE	DESCRIPTION	BY
1	20-12-2019	ISSUED FOR APPROVAL	

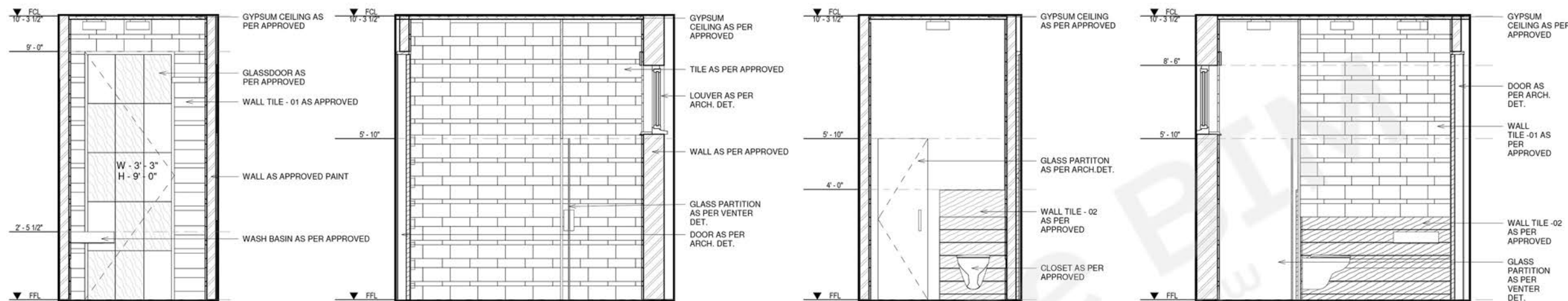

A Elevation - A
1 : 25

B Elevation - B
1 : 25

C Elevation - C
1 : 25

D Elevation - D
1 : 25

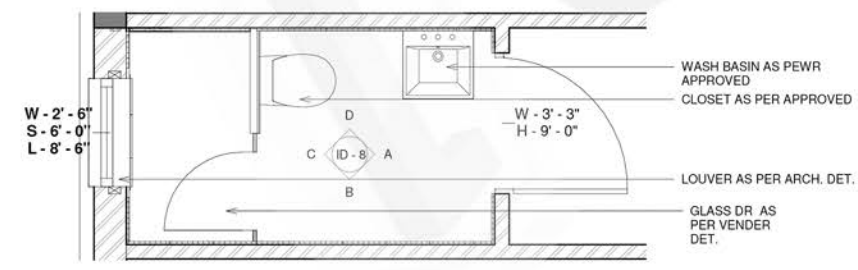

1 GF_TOILET-1 PLAN
1 : 25

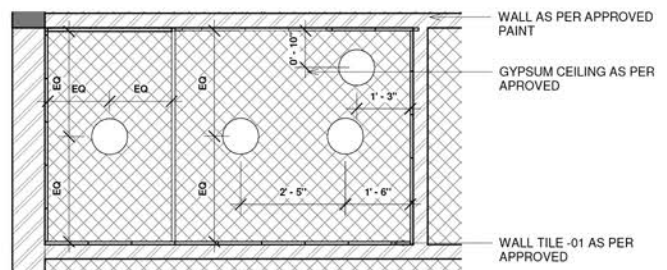

2 GF_TOILET -1 RCP
1 : 25



RENDER IMAGE - 01

BIM CONSULTANT

CLIENT

DEVELOPMENT MANAGER

CONTRACTOR

PROJECT

DRAWING TITLE
BEDROOM -01 - TOILET

SCALE	DATE	DRAWN	CHECKED
JOB	DRAWING	REVISION	
	ID - 8	1	



Centrelines BIM
Designing better, Tomorrow

THANK YOU

WWW.CENTRELINEBIM.COM



+91 95440 55556



WRITEUS@CENTRELINEBIM.COM

